

LVM12P02BSI

IP67 Snap In Vent

IP67 breathable vent plug with cost saving snap in feature offering reliable pressure equalisation to prevent condensation inside sealed enclosures. By balancing internal and external pressure, they protect against moisture, corrosion, and short circuits, eliminating the need for costly heating or ventilation systems. Featuring durable, breathable ePTFE membranes, these solutions enhance safety, extend service life, and reduce maintenance in harsh environments.



- ▶ IP67 protection and vibration resistant
- ▶ 300ml p/min / 18L p/hr air permeability @70kPa
- ▶ Water entry pressure 90kPa
- ▶ High-performance ePTFE hydrophobic membrane
- ▶ For panel thickness 0.55mm to 3.5mm
- ▶ Black PBT material
- ▶ Protects against internal water condensation
- ▶ Minimizes corrosion and wear inside enclosures
- ▶ Provides ventilation without compromising IP67 ingress protection
- ▶ Reduce servicing costs
- ▶ Ideal for outdoor lighting, marine, industrial, and temperature-variable settings.

Specifications & Materials:

Material	PBT
IP Rating	IP67
Colour	Black
Air permeability @ 70kPa (ml/min)	300
Airpermeability @ 70kPa (L/hr)	18
Thread	Snap-in
Temperature Range	-40°C to +90°C
Panel Cut Out (mm)	7.3
Panel Thickness Max. (mm)	0.5 - 3.5

LVM12P02BSI

IP67 Snap In Vent

LVM12P02BSI



Dimensions

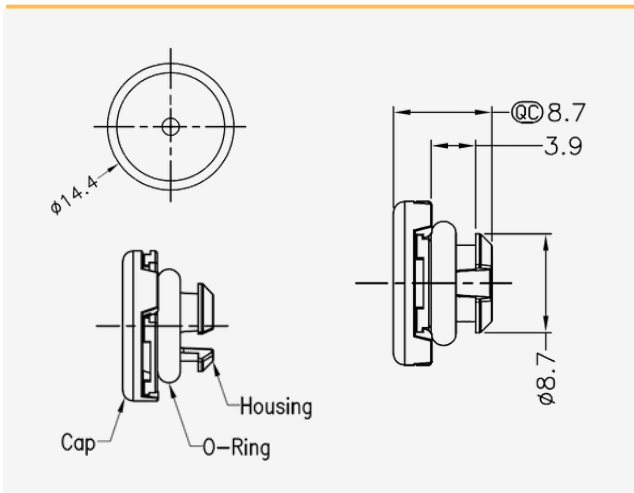

Panel Cut Out

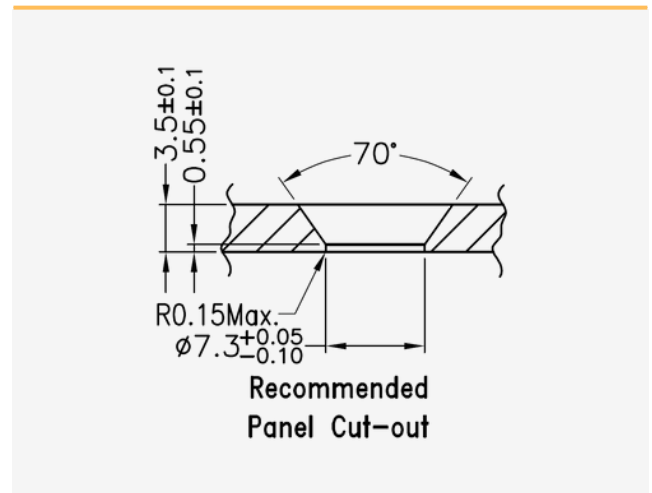

Part numbers

Part Number	Material	IP Rating	Air permeability @ 70kPa	Temperature Rating
LVM12P02BSI	PBT Black	IP67	300ml/min or 18L/hr	-40°C to +90°C

Also available

M12 Vent Brass / Stainless Steel



M12 Vent Nylon

