

嘉尼企業股份有限公司 CANAL ELECTRONIC CO.,LTD.

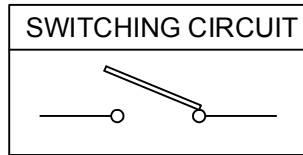

ROCKER SWITCH MODEL MR SERSIE

RATING: 16A/6~30VDC (cURus, ENEC15)
 DIELECTRIC WITHSTAND VOLTAGE: 1500VAC FOR 1 MINUTE
 INSULATION RESISTANCE: 500VDC 100MΩ (MIN.)
 CONTACT RESISTANCE: 20mΩ INITIAL(MAX.)

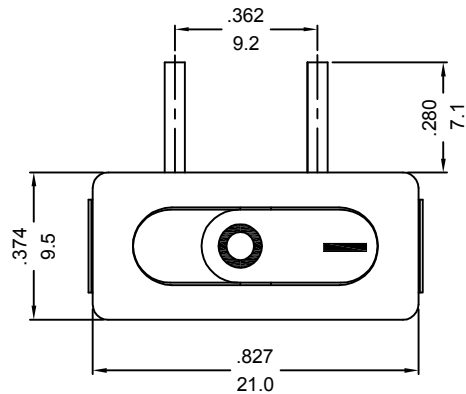
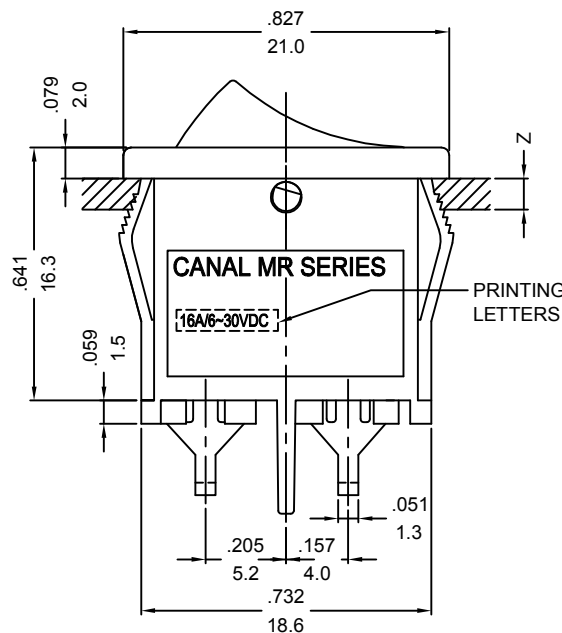

PRINTING LETTERS

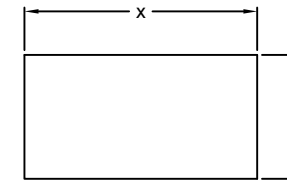
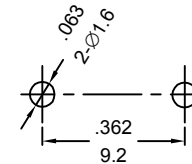
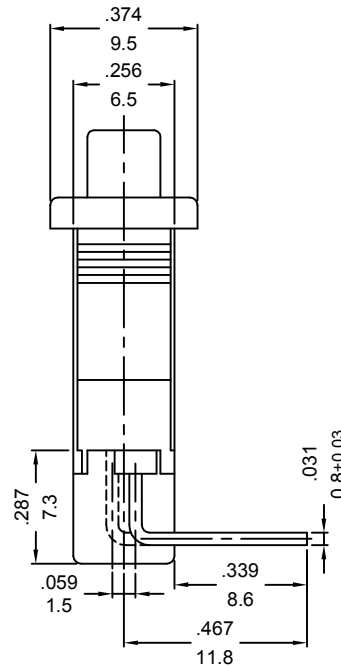

PANEL CUTOUT DIMENSION TABLE

X(CUTOUT DIMENSION)	Y(CUTOUT DIMENSION)	Z(PANEL THICKNESS)
19.2 ^{+0.15} ₋₀ mm	6.65~6.75mm	0.75~1.25mm
19.4 ^{+0.15} ₋₀ mm	6.65~6.75mm	1.25~2mm
19.8 ^{+0.15} ₋₀ mm	6.65~6.75mm	2~3mm

MODEL NO, SEE NUMBER SYSTEM

NOTE: TOLERANCES UNLESS OTHERWISE SPECIFIED: ± .012/0.3 (in/mm)

REVISION	DESCRIPTION	REVISED BY	TOLERANCES		ANGLE 1/2°	UNIT	mm	PART NAME	MR SPEC DRAWING	DWG NO
			DRAWN BY	DESIGNED BY	SCALE					S9055A
△			楊偉韶	蔡劍		2/1				
△										
△										
△	2022.11.24 首次出圖	楊偉韶	CHECKED BY	APPROVED BY	DATE	2022.11.24	PART NO	MR-H12C5W-NBBD-CFNC		