

嘉尼企業股份有限公司 CANAL ELECTRONIC CO.,LTD.

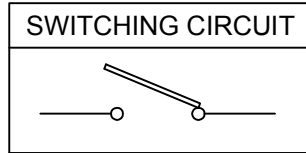
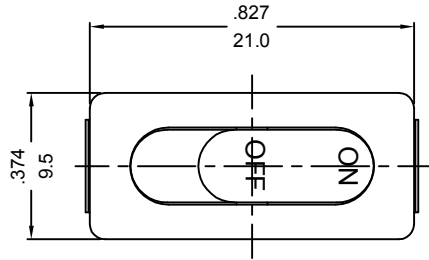

ROCKER SWITCH MODEL MR SERSIE

RATING: 16A 30VDC (cURus/ENEC15)

10(4)A 250V~T125/55 (CQC)

DIELECTRIC WITHSTAND VOLTAGE: 1500VAC FOR 1 MINUTE

INSULATION RESISTANCE: 500VDC 100MΩ (MIN.)

CONTACT RESISTANCE: 20mΩ INITIAL (MAX.)

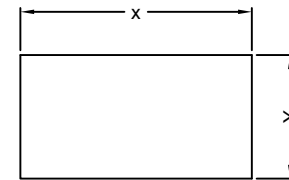
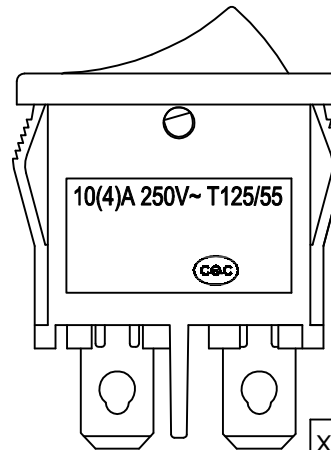
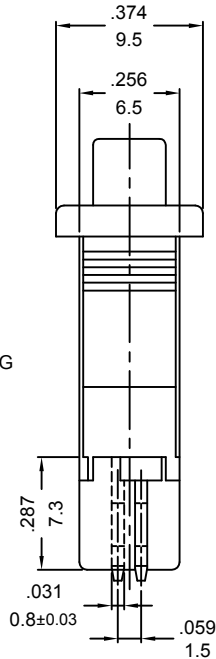
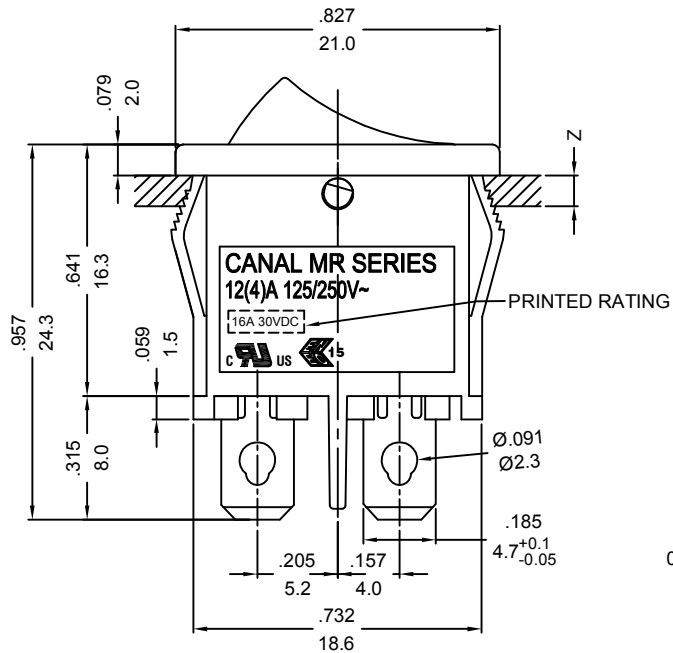

PANEL CUTOUT DIMENSION TABLE

X(CUTOUT DIMENSION)	Y(CUTOUT DIMENSION)	Z(PANEL THICKNESS)
19.2 ^{+0.15} ₋₀ mm	6.65~6.75mm	0.75~1.25mm
19.4 ^{+0.15} ₋₀ mm	6.65~6.75mm	1.25~2mm
19.8 ^{+0.15} ₋₀ mm	6.65~6.75mm	2~3mm

NOTE: TOLERANCES UNLESS OTHERWISE SPECIFIED: ± .012/0.3 (in/mm)

MODEL NO, SEE NUMBER SYSTEM

REVISION	DESCRIPTION	REVISED BY	TOLERANCES		ANGLE 1/2°		UNIT	mm	PART NAME	MR SPEC DRAWING	DWG NO
			DRAWN BY	DESIGNED BY	SCALE						
△			楊偉韶	蔡劍		2/1					S9567A
△					DATE	2023.11.07		PART NO	MR-H11C3W-NBBD-1FNC		
△	2023.11.07 首次出圖	楊偉韶									