

嘉尼企業股份有限公司 CANAL ELECTRONIC CO.,LTD.

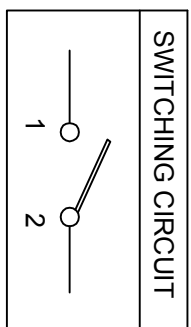

ROCKER SWITCH MODEL:RH SERIES
 RATING: 16(8)A 125/250V~ (cURus)
 8[128] 250VAC (cURus)
 16(8)A 250V~ T125/55 (ENEC15/CQC)
 DIELECTRIC WITHSTAND VOLTAGE: 1500VAC 1 MINUTE
 INSULATION RESISTANCE: 500VDC 100M Ω (MIN)
 CONTACT RESISTANCE: 20m Ω INITIAL (MAX.)

(LEGEND COLOR: WHITE)

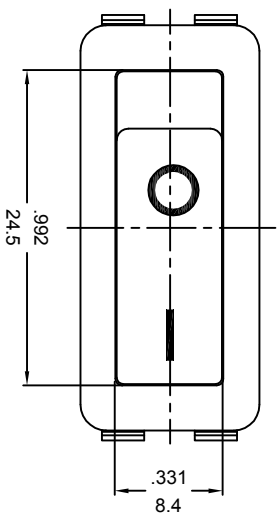
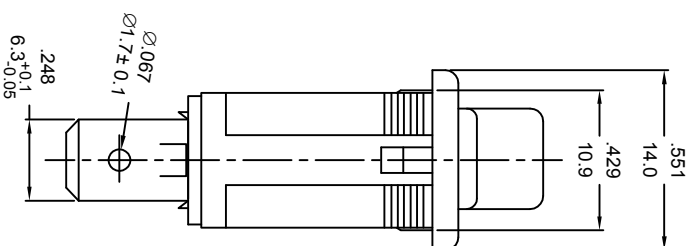
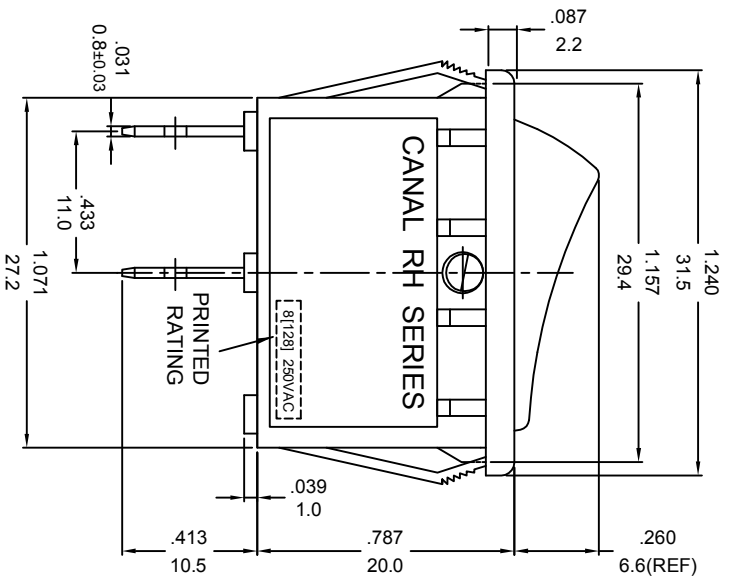

Description	Material	Color	Flammability
Actuator	Nylon 66	Black	UL94 V-0
Base	Nylon 66	Black	UL94 V-0

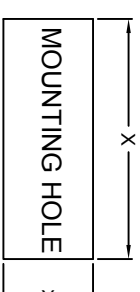

Dim. X	Dim. Y	Z=panel thickness
30.0 ^{+0.1} ₀ mm	11.0 ^{+0.1} ₀ mm	0.75 to 1.25mm
30.2 ^{+0.1} ₀ mm	11.0 ^{+0.1} ₀ mm	1.25 to 2mm
30.5 ^{+0.1} ₀ mm	11.0 ^{+0.1} ₀ mm	2 to 3mm

NOTE:TOLERANCES UNLESS OTHERWISE SPECIFIED:± .012/0.3 (in/mm)

REVISION	DESCRIPTION	REVISED BY	TOLERANCES		ANGLE	SCALE	UNIT	PART NAME	RH SPEC DRAWING	DWG NO
			DRAWN BY	CHECKED BY						
△			达志各		蔡剑	5/3	mm			LS0002A
△										
△										
△										
△	首次出圖	达志各						R-H10C5W-NBBF-16ANC-V0		