

嘉尼企業股份有限公司 CANAL ELECTRONIC CO.,LTD.

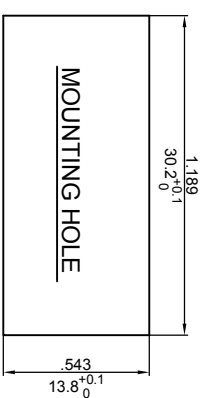
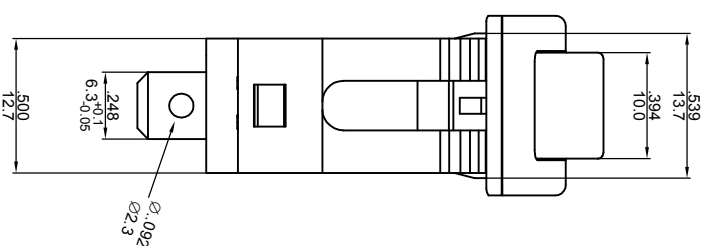
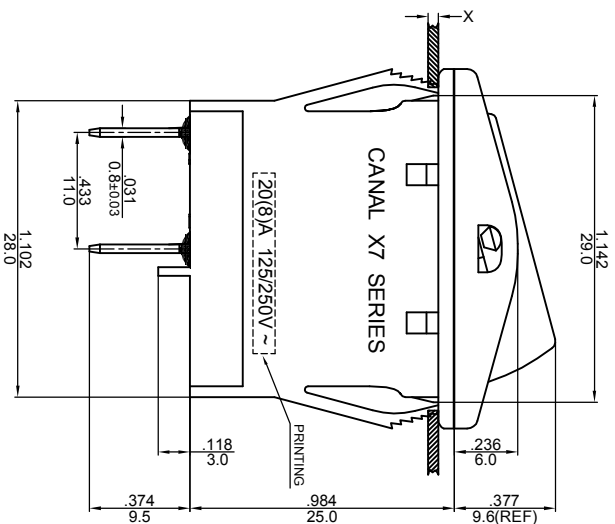
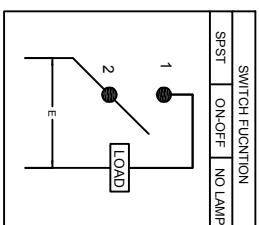
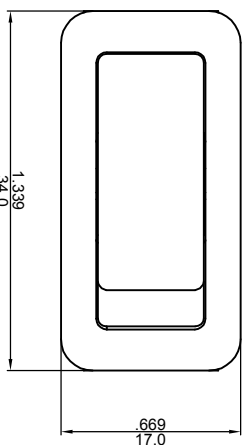

X=(0.8~3.0mm)
PANEL THICKNESS

NOTE: TOLERANCES UNLESS OTHERWISE SPECIFIED:±.012/0.3 (in/mm)

REVISION	DESCRIPTION	REVISED BY	TOLERANCES		ANGLE		SCALE	UNIT	PART NAME	PART NO	DWG NO
			DRAWN BY	CHECKED BY	DESIGNED BY	APPROVED BY					
△			达志各		蔡劍		3/2	mm	X7 SPEC DRAWING	X7-H11F2N-NBBB-5NWC	S8247A
△											
△											
△	2020.10.21	首次出圖	达志各				2020.10.21				