

# 嘉尼企業股份有限公司 CANAL ELECTRONIC CO., LTD.

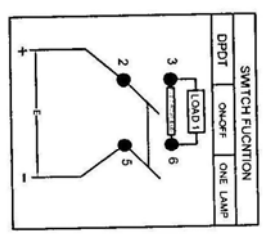

**ROCKER SWITCH MODEL: X7 SERIES**  
 RATING: 16(8)A 125/250VAC ~ (CJRus)  
 DIELECTRIC WITHSTAND VOLTAGE: 1500VAC 1 MINUTE  
 INSULATION RESISTANCE: 500VDC 100M Ω (MIN)  
 CONTACT RESISTANCE: 20m Ω INITIAL (MAX.)  
 ILLUMINATION: 100~125VAC  
 WATERPROOF GRADE: IP67

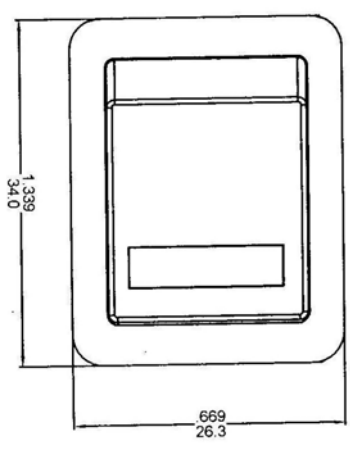
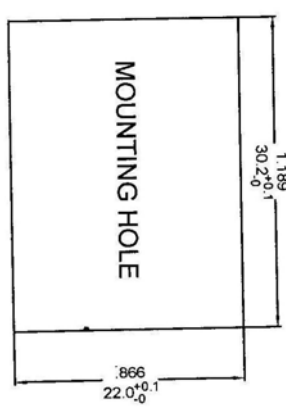
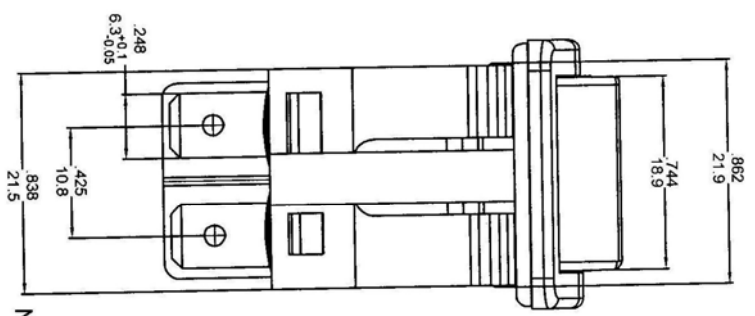
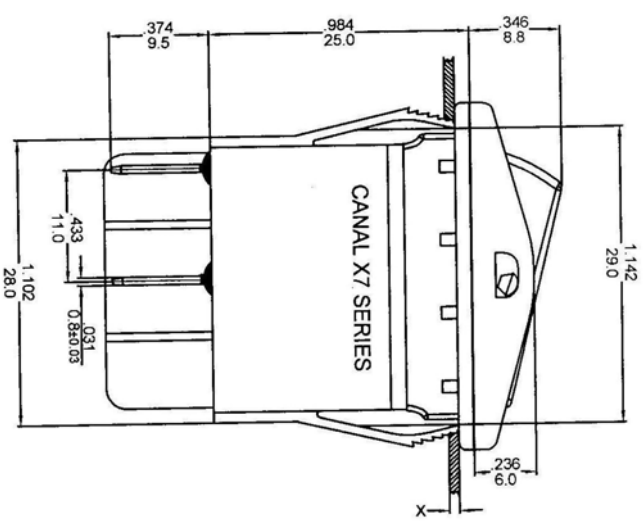

X=(0.8~3.0mm)  
 PANEL THICKNESS



NOTE: TOLERANCES UNLESS OTHERWISE SPECIFIED: ±.012/0.3 (in/mm)

REVISION	DESCRIPTION	REVISED BY	TOLERANCES	ANGLE	SCALE	UNIT	PART NAME	PART NO	DWG NO
△			DRAWN BY 達志各	蔡劍	3/2	mm	X7 SPEC DRAWING		S7924A
△			CHECKED BY						
△			DESIGNED BY 達志各						
△			APPROVED BY						
△	2019.11.08 首次出圖	達志各					X7-210F2N-LBBA-1WWC		