



ZIPPY TECHNOLOGY CORP.



10F, NO.50, MIN CHYUAN ROAD,
SHIN-TIEN CITY, TAIPEI COUNTY,
TAIWAN, R.O.C

TEL: 886-2-2918-8512 / 886-2-2918-0603
FAX: 886-2-2915-5765 / 886-22916-0215
[Http://www.zippy.com.tw](http://www.zippy.com.tw)

APPROVED DATA SHEET

=====
Model:1001640012(DW32-P1H-00A2-MF001A-Z)
=====

ISSUED DATE: 2020.02.24

APPROVED NO.: 1001640012.A

PAGE: 1/5

The undersigned guarantee of the model switches is meets the following specifications.

1.Operation Characteristics

- Operating Force (OF) : Max. 160 gf Indicates operating load for NC contact to achieve Off status
Free Position (FP) : Max. 7.7 mm
Operating Position on NC side (OP) : 7.1±0.25 mm Indicates postion for NC contact to achieve Off status
Over-travel : 1.75 mm(ref.)

2. Specifications

- Initial Contact Resistance : Max. 600mΩ. Before measure the switch contact resistance, please press the switch three times on and off.
Initial Dielectric Strength : 500VAC(50-60HZ)/minute between contacts. 1500VAC(50-60HZ)/minute between Live-parts and dead metal parts.
Insulation Resistance : Min. 100 MΩ(500 VDC/ minute) between Live-parts and dead metal parts.
Circuit Arrangement : SPST (Single pole single throw)
Rating & Service Life : 50mA 16VDC - Min. 150,000 operations. 1mA 5VDC - Min. 300,000 operations. 100mA 12VDC - Min. 300,000 operations
Rating Load : Resistive Load.
Operating Frequency : Max.120 operations per minute.
Operating application of the switch : Set the switch pushing distance from 60% to 90% of the specified OT value.
Protection : IP67



ZIPPY TECHNOLOGY CORP.



10F, NO.50, MIN CHYUAN ROAD,
SHIN-TIEN CITY, TAIPEI COUNTY,
TAIWAN, R.O.C

TEL: 886-2-2918-8512 / 886-2-2918-0603
FAX: 886-2-2915-5765 / 886-22916-0215
[Http://www.zippy.com.tw](http://www.zippy.com.tw)

APPROVED DATA SHEET

Model:1001640012(DW32-P1H-00A2-MF001A-Z)
=====

ISSUED DATE: 2019.12.26
APPROVED NO.: 1001640012.A
PAGE: 2/5

3. Environments

Operating Temperature : -40°C~85°C (with no icing)
Shock Resistance : Destruction: 1,000 m/s² {approx. 100G} max.
Malfunction: 300 m/s² {approx. 30G} max.

(For the pin plunger models, the vibration & shock condition apply for use at the free position and total travel position)
(For the lever models, the vibration & shock condition apply for use at the total travel position)

Vibration Resistance : 10~55Hz, displacement 0.75mm(p-p)
Soldering by hand : 350°C maximum with in 3 seconds.
Soldering by bath : 260°C maximum with in 5 seconds

ZIPPY TECHNOLOGY CORP.

簡素玲

PREPARED

黃俊嘉

CHECKED

倪有庭

APPROVED

Dimensions drawing

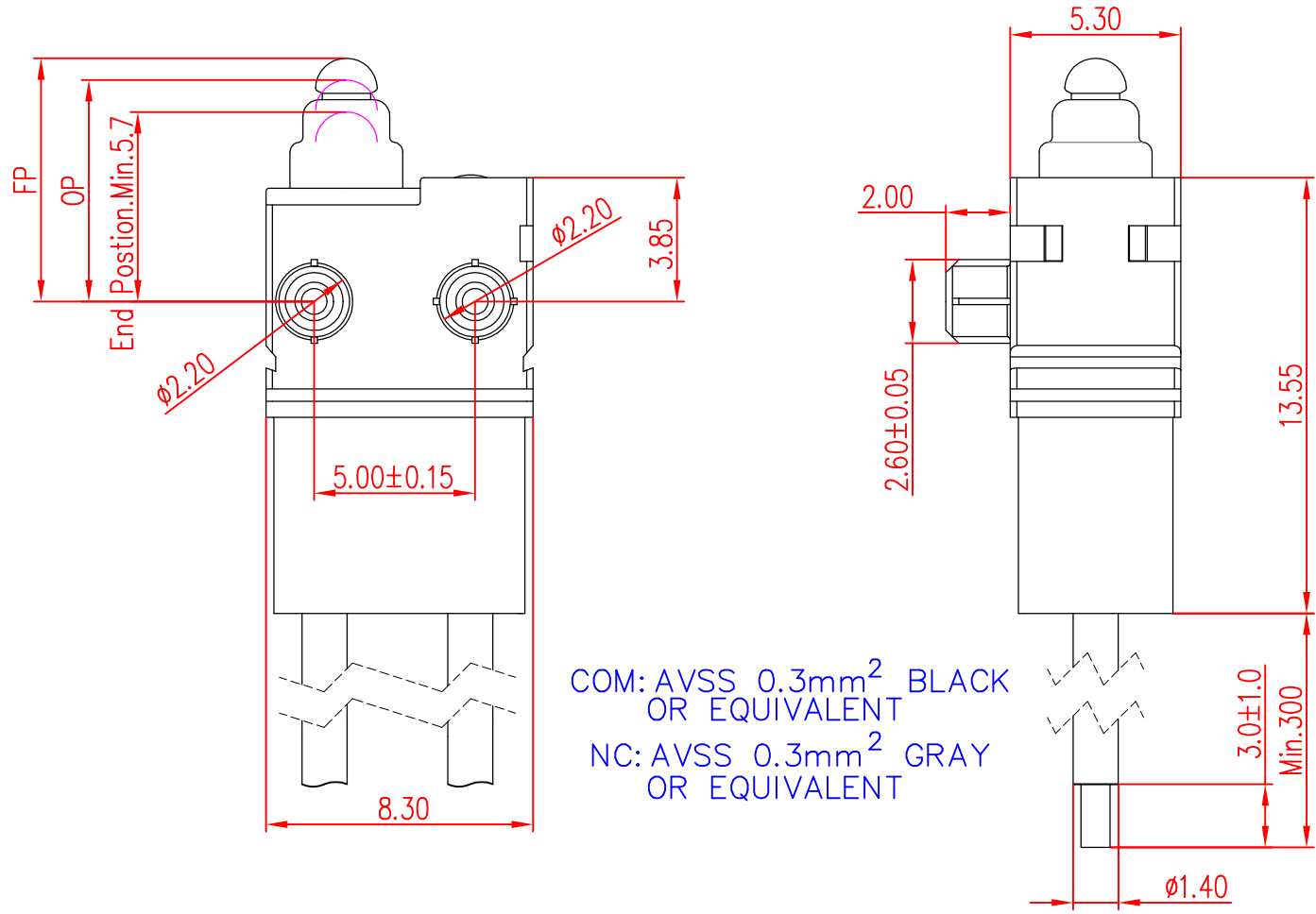

Tolerance	
X. X	± 0.2
XX. X	± 0.4

VIEW		SIZE	A4	UNIT	mm
DATE	2020.02.24	VER.	1.0	FILE NAME	DW32-00A2-MF001A
APPROVAL	倪有庭	CONFIRM	歐大揮	DESIGN	黃俊嘉

Dimensions drawing

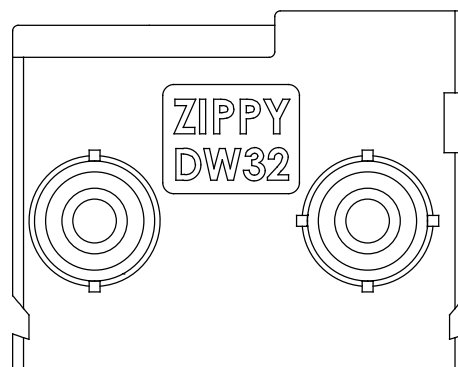

Tolerance	
X.X	± 0.2
XX.X	± 0.4

VIEW		SIZE	A4	UNIT	mm
DATE	2019.01.07	VER.	1.0	FILE NAME	DW32-00
APPROVAL	張哲維	CONFIRM	歐大揮	DESIGN	黃俊嘉

新巨企業股份有限公司

ZIPPY TECHNOLOGY CORP.

CAUTIONS:

注意事項

Terminal EC, ED, YC, and YD are not designed for soldering. Please do not solder wires with these terminal types.

端子型式EC, ED, YC 以及YD 不適用於焊線或焊接。

1: Do not handle the switch in a way that may cause damage to the sealed rubber & switch sealing.

使用開關時，請勿損壞開關防水矽膠罩及開關防水膠。

2: Wires should not be dragged.

使用帶線型式時，請注意避免拉扯線材。

3: To ensure the best performance of the switch, when handling/installing the switch, please do not apply uneven pressure to the direction indicated by the arrow in (Figure 1). Any uneven pressure or pressure direction other than the operating direction might be harmful or damage the switch performance.

為確保開關正常運作，安裝及取用開關時，請勿直接施加壓力在(圖-1)中箭頭所指示的方向。如圖所示，任何不對稱的壓力或作動方向以外的壓力都不適用在開關按柄上。

4: Do not exceed the end position (EP) and over travel (OT). This could cause operation failure.

設計按壓位置，請勿超過開關下死點及超出行程，以避免開關失效。

5: Avoid applying any grease/oil and chemicals on the switch rubber.

請避免沾附任何油脂或者化學物質在開關的矽膠防水罩上。

6: < Important > To prevent deterioration of contact reliability, fork terminals should not be deformed in any situation. In order to prevent the deformation of the fork terminals, please use a special tooling to keep the switch vertical to the actual equipment. When inserting the fork terminal to the actual equipment, please make sure the fork terminal is well-supported, As shown in (Figure-2)

<重要>為防止叉形端子變形而導致接觸可靠性下降，應使用專用工具安裝叉形端子開關，以使其保持垂直於實際設備的狀態，並在支撐端子的同時插入端子。建議安裝方式請參照(圖-2)。

7: < Suggestion > After the installation of the switch, please seal the terminal part properly to prevent the deterioration of the contact reliability due to vibration, impact, humidity and gas. Before the sealing process, please make sure the fork terminal fixed on the equipment. Please selection a sealing material that does not cause sulfuration, oxidation or generation of low molecular siloxane gas.

<建議>在端子部上使用密封材料，將開關完全固定並密封端子部，以防止由於開關的叉形端子和實際設備的端子因振動、衝擊、潮濕和氣體而導致連接部分的接觸可靠性下降。(切勿使用未密封的開關。)此外，有必要選擇不會引起硫化、氧化或低分子矽氧烷氣體生成的密封材料，因為存在因密封材料而導致接觸失敗的風險。為了選擇密封材料，應事先通過實際設備進行充分驗證。

8: < Important > The contact reliability may highly deteriorate due to unmatched materials or inaccurate of the connection between fork terminal and the matting equipment. Please contact your Zippy representative before using fork terminal type switch.

<重要>由於使用不匹配的材料或叉形端子與設備裝配不精準，端子連接部分的接觸可靠性可能會大大降低。如果您考慮使用叉形端子類型，請務必諮詢我們。

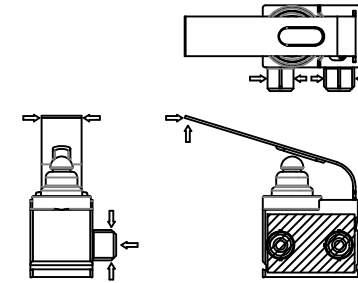

Figure-1

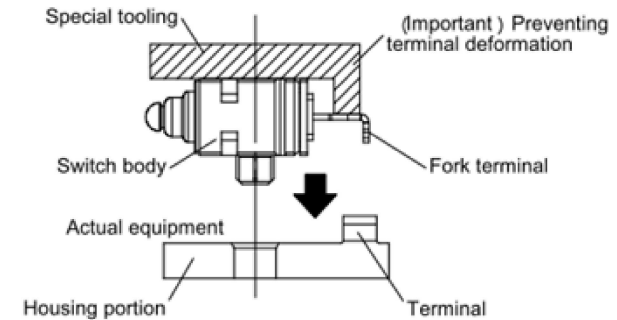

Figure-2

△	DATE	APPROVAL	DESIGN	ENGINEERING CHANGE DESCRIPTION	VIEW	SIZE	A4	UNIT	mm	
新巨企業股份有限公司					DATE	2019.12.16	VER.	1.0	FILE NAME	DW32-CAUTIONS
					APPROVAL	倪有庭	CONFIRM	歐大揮	DESIGN	黃俊嘉

新巨企業股份有限公司

ZIPPY TECHNOLOGY CORP.