



ZIPPY TECHNOLOGY CORP.



10F, NO.50, MIN CHYUAN ROAD,  
SHIN-TIEN CITY, TAIPEI COUNTY,  
TAIWAN, R.O.C

TEL: 886-2-2918-8512 / 886-2-2918-0603  
FAX: 886-2-2915-5765 / 886-22916-0215  
[Http://www.zippy.com.tw](http://www.zippy.com.tw)

### APPROVED DATA SHEET

-----  
**Model: 1001240184(VW1-10S1-06A0-CB001-Z)**  
=====

ISSUED DATE: 2019.03.11  
APPROVED NO.: 1001240184.B  
PAGE: 1/4

The undersigned guarantee of the model switches is meets the following specifications.

#### 1.Operation Characteristics

Operating Force (OF) : Max. 130 gf  
Releasing Force (RF) : Min. 20 gf  
Operating Position (OP) : 20.4±0.7 mm  
Movement Differential (MD) : Max. 0.7 mm  
Over-travel (OT) : Min. 1.3 mm  
Pre-travel (PT) : Max. 3.3 mm

#### 2. Specifications

Initial Contact Resistance : Max. 300 mΩ . (Initial) (For molded lead wire models)  
( Measured by ohm meter –Open Voltage<1VDC, Driver current -100mA )  
Before measure the switch contact resistance, please press the switch three times on and off.

Initial Dielectric Strength : 500VAC(50-60HZ)/minute between contacts.  
1,500VAC(50-60HZ)/minute between Live-parts and dead metal parts.

Insulation Resistance : Min. 100 MΩ ( 500 VDC/ minute ).

Circuit Arrangement : SPDT ( Single pole double throw )

Rating : 10A 125/250VAC ; 5A 30VDC

Service Life : Min. 10,000 operations.

Operating Frequency : 10~30 operations per minute.

Safety Certificate : UL, cUL, ENEC

Mechanical Service Life : Min. 1,000,000 operations.

Operating Frequency : Max. 120 operations per minute.

Operating application of the switch : Set the switch pushing distance from 60% to 90% of the specified OT value.

International Protection Code : IP67



ZIPPY TECHNOLOGY CORP.



10F, NO.50, MIN CHYUAN ROAD,  
SHIN-TIEN CITY, TAIPEI COUNTY,  
TAIWAN, R.O.C

TEL: 886-2-2918-8512 / 886-2-2918-0603  
FAX: 886-2-2915-5765 / 886-22916-0215  
[Http://www.zippy.com.tw](http://www.zippy.com.tw)

### APPROVED DATA SHEET

-----  
**Model: 1001240184(VW1-10S1-06A0-CB001-Z)**  
=====

ISSUED DATE: 2019.03.11  
APPROVED NO.: 1001240184.B  
PAGE: 2/4

### 3. Environments

- Operating Temperature : -40°C ~ 85°C ( with no icing )
- Vibration Resistance : 10~55Hz, displacement 0.75mm(p-p) 2hr
- Shock Resistance : Destruction: 1,000 m/s<sup>2</sup> {approx. 100G} max.  
Malfunction: 300 m/s<sup>2</sup> {approx. 30G} max.

( For the pin plunger models, the vibration & shock condition apply for use at the free position and total travel position )

( For the lever models, the vibration & shock condition apply for use at the total travel position )

- Soldering by hand : 350 °C maximum within 3 seconds.

**Note: Wires should not be dragged.**

ZIPPY TECHNOLOGY CORP.

許志誠

-----  
PREPARED

張奕鉸

-----  
CHECKED

沈俊榮

-----  
APPROVED

Dimensions drawing

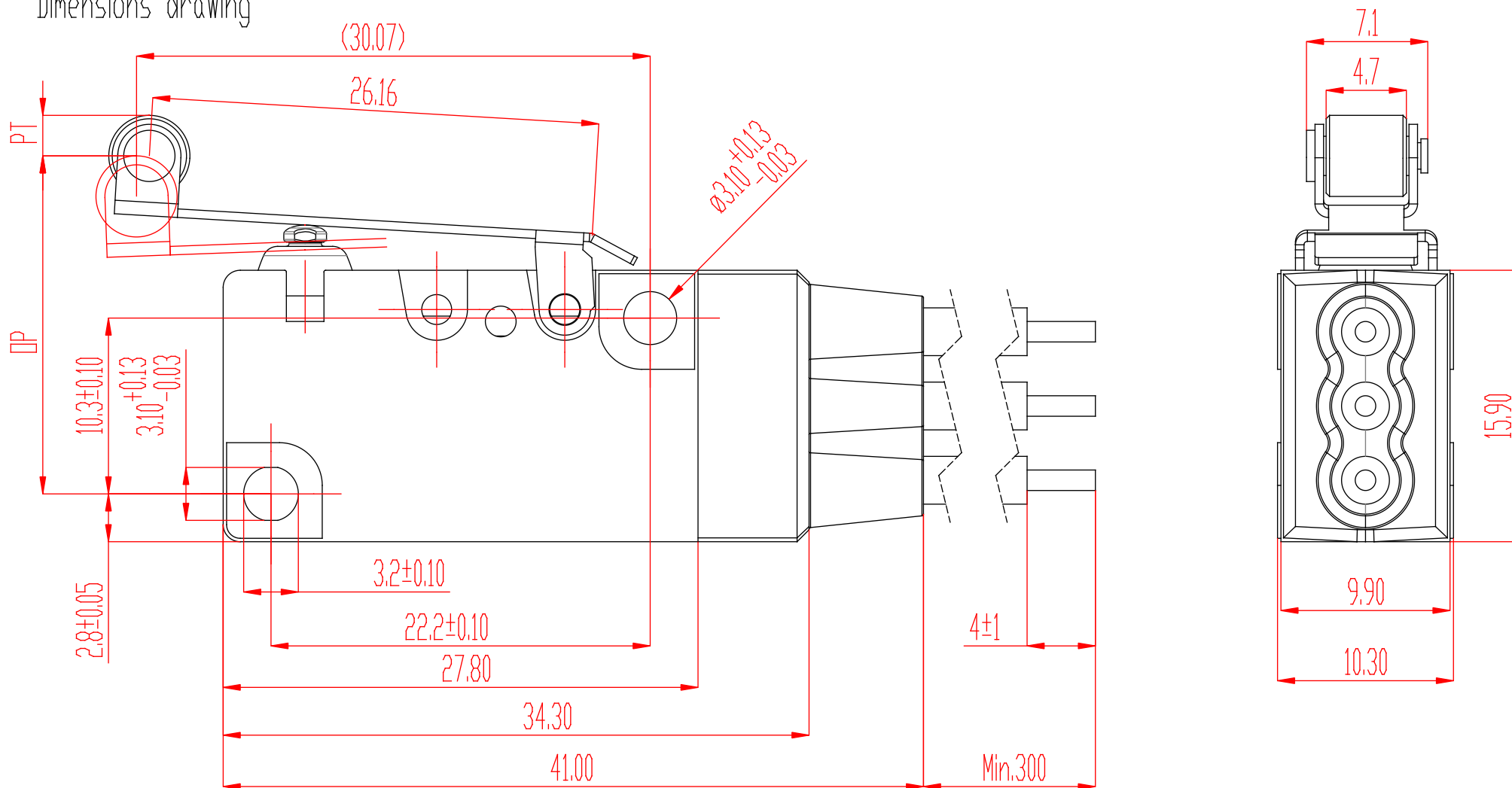

COM : BLACK / UL1015 16AWG OR EQUIVALENT  
 NO : BLUE / UL1015 16AWG OR EQUIVALENT  
 NC : RED / UL1015 16AWG OR EQUIVALENT

Tolerance	
X.X	± 0.2
XX.X	± 0.4

VIEW		SIZE	A4	UNIT	mm
DATE	NOV-09-2015	VER.	1.1	FILE NAME	VW1-06A0-R-CB001
APPROVAL	沈俊榮	CONFIRM	張奕鉸	DESIGN	許志誠

Marking drawing

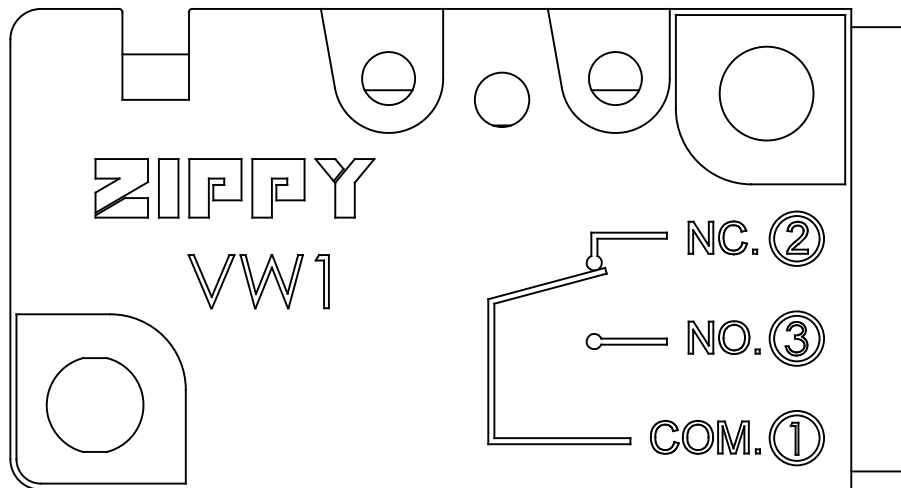

obverse side

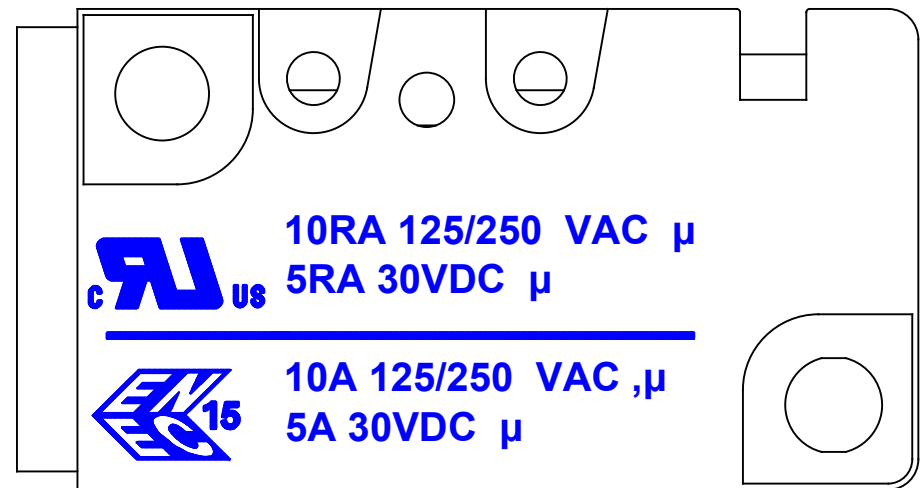

reverse side

Markings are either by printing or molding

新巨企業股份有限公司

**ZIPPY** TECHNOLOGY CORP.

VIEW		SIZE	A4	UNIT	mm
DATE	2019.02.18	VER.	1.0	FILE NAME	VW1-10-u
APPROVAL	沈俊榮	CONFIRM	張奕鉸	DESIGN	許志誠