



ZIPPY TECHNOLOGY CORP.



10F, No.50, MinQuan Road, Xindian District,
New Taipei City, Taiwan, R.O.C

TEL: 886-2-2918-8512 / 886-2-2918-0603
FAX: 886-2-2915-5765 / 886-22916-0215
[Http://www.zippy.com.tw](http://www.zippy.com.tw)

APPROVED DATA SHEET

Model: 1001610033(SW2-06S0-00A0-Z)

ISSUED DATE: 2020.01.06
APPROVED NO. 1001610033.C
PAGE: 1/5

The undersigned guarantee of the model switches is meets the following specifications.

1.Operation Characteristics

- Operating Force (OF) : Max. 203 gf
- Releasing Force (RF) : Min. 50 gf
- Free Position (FP) : Max. 9.9 mm
- Operating Position (OP) : 8.4±0.3 mm
- Movement Differential (MD) : Max. 0.2 mm
- Over-travel (OT) : Min. 0.4 mm
- Pre-travel (PT) : Max. 1.2 mm

2. Specifications

- Initial Contact Resistance : Max. 300mΩ.
(Measured by ohm meter –Open Voltage<1VDC, Driver current -100mA)
Before measure the switch contact resistance, please press the switch three times on and off.
- Initial Dielectric Strength : 500VAC(50-60HZ)/minute between contacts.
1,500VAC(50-60HZ)/minute between Live-parts and dead metal parts.
- Insulation Resistance : Min. 100MΩ (500 VDC/ minute) between Live-parts and dead metal parts.
- Circuit Arrangement : SPDT (Single pole double throw)
- Rating : 6A 125/250VAC
5A 30VDC (Resistive Load)
- Service Life : Min. 10,000 operations.
- Rating Load : Resistive (R) Load & Inductive (GP) Load.
- Operating Frequency : 10~30 operations per minute.
- Safety Certificate : UL, cUL, ENEC

- Mechanical Service Life : Press the switch to operation position - Min. 2,000,000 operations.
- Operating Frequency : Max. 120 operations per minute.
- Operating application of the switch : Set the switch pushing distance from 60% to 90% of the specified OT value.



ZIPPY TECHNOLOGY CORP.



10F, No.50, MinQuan Road, Xindian District,
New Taipei City, Taiwan, R.O.C

TEL: 886-2-2918-8512 / 886-2-2918-0603
FAX: 886-2-2915-5765 / 886-22916-0215
[Http://www.zippy.com.tw](http://www.zippy.com.tw)

APPROVED DATA SHEET

Model: 1001610033(SW2-06S0-00A0-Z)

ISSUED DATE: 2020.01.06
APPROVED NO. 1001610033.C
PAGE: 2/5

3. Environments

Operating Temperature	:	-40°C ~ 125°C (with no icing)
Vibration Resistance	:	10~55Hz, displacement 0.75mm(p-p)
Shock Resistance	:	Destruction: 1,000 m/s ² {approx. 100G} max. Malfunction: 300 m/s ² {approx. 30G} max.

(For the pin plunger models, the vibration & shock condition apply for use at the free position and total travel position)

(For the lever models, the vibration & shock condition apply for use at the total travel position)

Soldering by hand	:	350°C maximum within 3 seconds (300°C maximum within 5 seconds).
Soldering bath	:	260°C maximum within 5 seconds.

ZIPPY TECHNOLOGY CORP.

卓妍蓁

PREPARED

陳立業

CHECHED

沈俊榮

APPROVED

Dimensions drawing

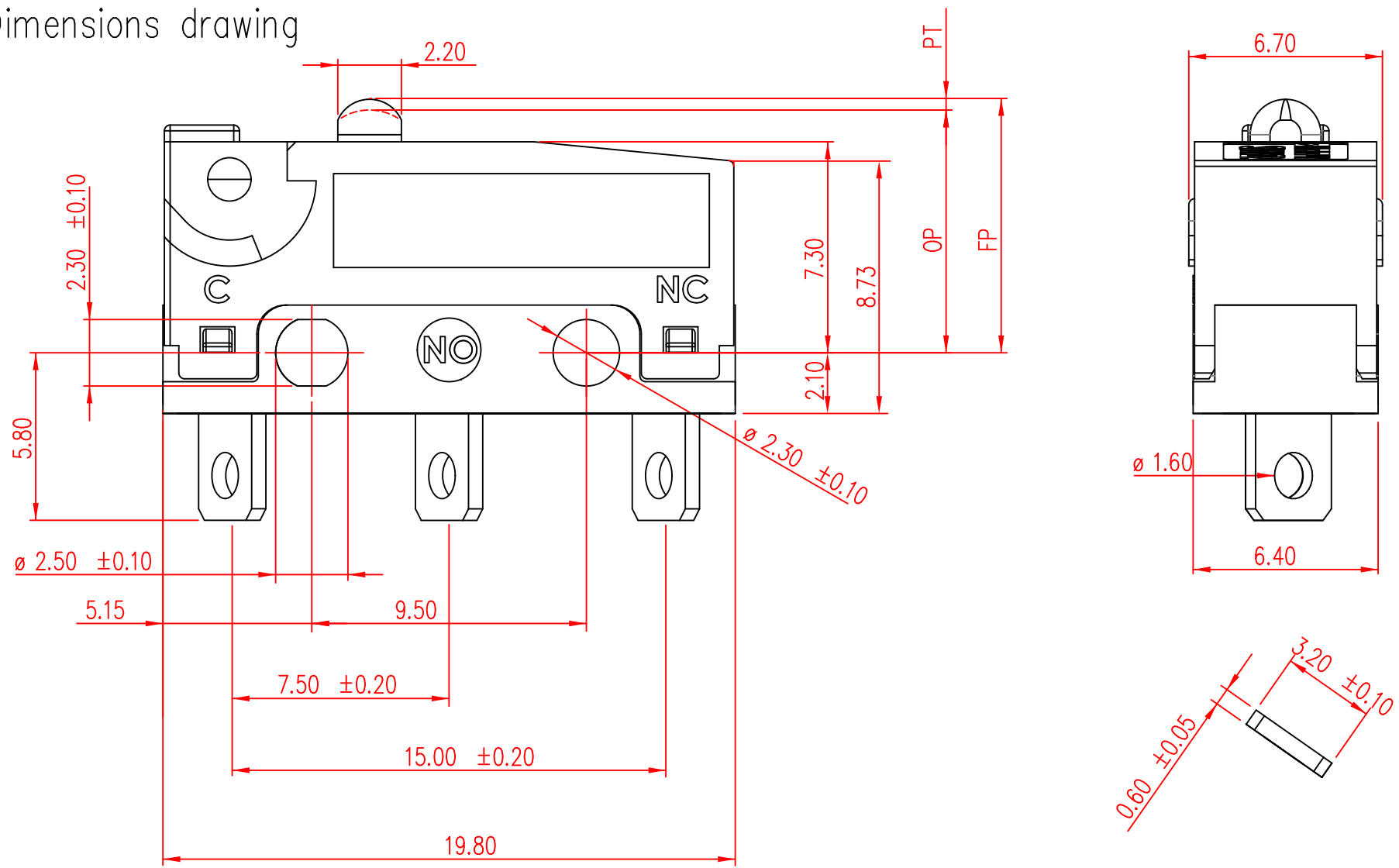

Tolerance	
X. X	± 0.2
XX. X	± 0.4

VIEW		SIZE	A4	UNIT	mm
DATE	FEB-03-2015	VER.	1.0	FILE NAME	SW2-000A0
APPROVAL	沈俊榮	CONFIRM	張立人	DESIGN	陳立業

新巨企業股份有限公司

ZIPPY TECHNOLOGY CORP.

Marking drawing

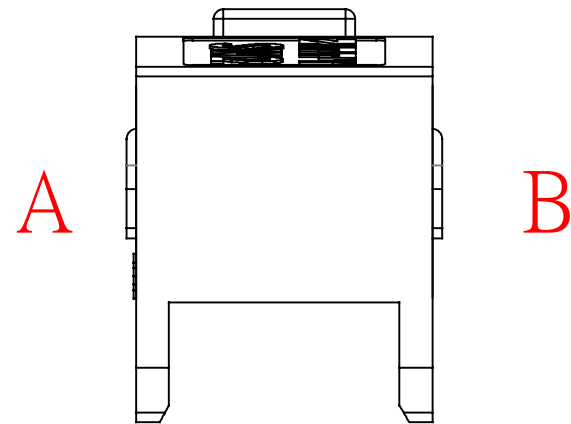
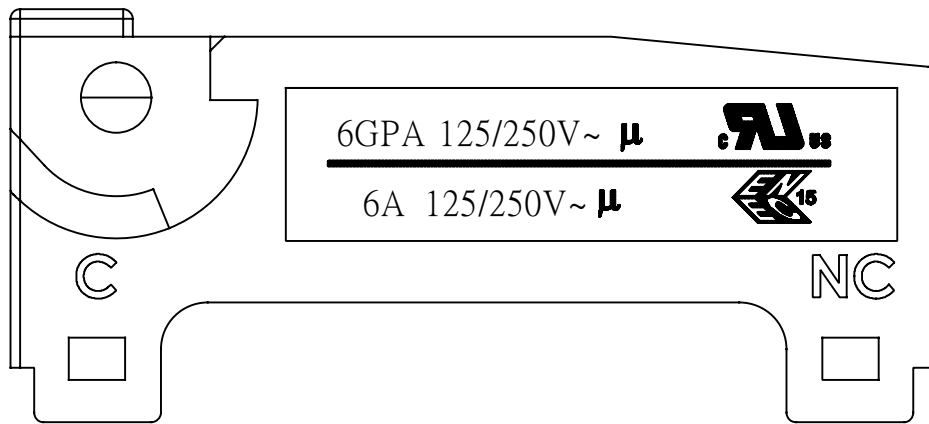
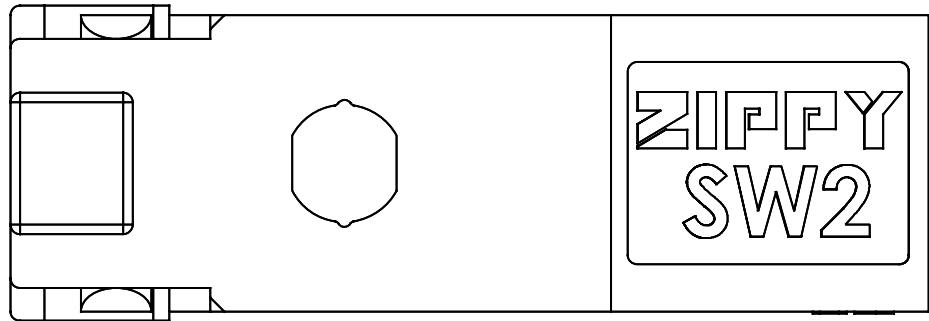

Marking will be random on side A or side B
 Markings are either by printing or molding
 Appearance according to dimensions drawing.

VIEW		SIZE	A4	UNIT	mm
DATE	AUG-27-2018	VER.	1.1	FILE NAME	SW2-060-u
APPROVAL	沈俊榮	CONFIRM	許志誠	DESIGN	陳立業

CAUTIONS:

注意事項

1: Wires should not be dragged.

使用帶線型式時，請注意避免拉扯線材。

2: To secure the switch, please use an M2.3 small screw on a flat surface and tighten with plane washers or spring washers to securely mount the Switch, using a maximum torque of 0.26 N·m.

若使用定位孔型式，請使用M2.3小型螺絲固定在平面上，並使用平墊圈或者彈性墊圈以便安全的鎖固開關，鎖固扭力請勿超過0.26 N·m.

3: Do not handle the Switch in a way that may cause damage to the sealed rubber & switch sealing.

使用開關時，請勿損壞開關防水矽膠罩及開關防水膠。

4: To ensure the best performance of the switch, when handling/installing the switch, please do not apply uneven pressure to the direction indicated by the arrow in (Figure -1). Any uneven pressure or pressure direction other than the operating direction might be harmful or damage the switch performance.

為確保開關正常運作，安裝及取用開關時，請勿直接施加壓力在(圖-1)中箭頭所指示的方向。如圖所示，任何不對稱的壓力或作動方向以外的壓力都不適用在開關按柄上。

5: Do not exceed the end position (EP) and over travel (OT). This could cause operation failure. (Figure-2)

圖示設計按壓位置，請勿超過開關下死點及超出行程，以避免開關失效。(圖-2)

6: Avoid applying any grease/oil and chemicals on the switch rubber.

請避免沾附任何油脂或者化學物質在開關的矽膠防水罩上。

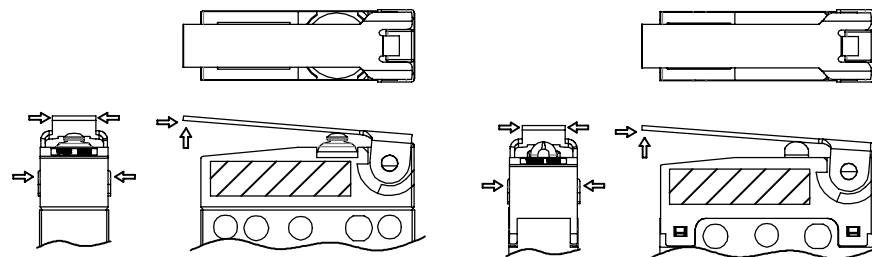

Figure-1

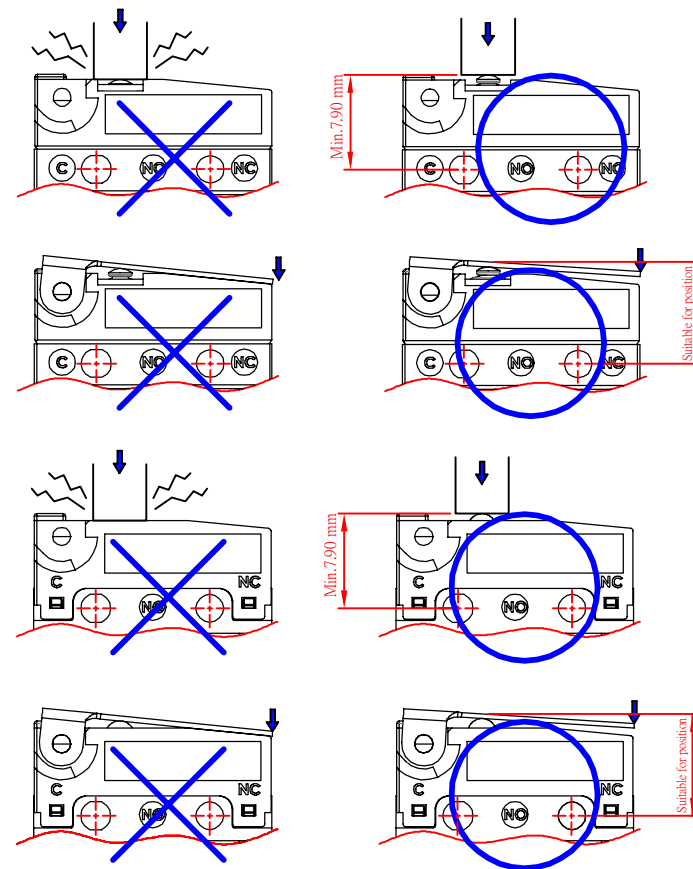

Figure-2

VIEW		SIZE	A4	UNIT	mm
DATE	2019.12.17	VER.	1.0	FILE NAME	SW2-CAUTIONS
APPROVAL	沈俊榮	CONFIRM	許志誠	DESIGN	陳立業