



ZIPPY TECHNOLOGY CORP.



10F, NO.50, MIN CHYUAN ROAD,
SHIN-TIEN CITY, TAIPEI COUNTY,
TAIWAN, R.O.C

TEL: 886-2-2918-8512 / 886-2-2918-0603
FAX: 886-2-2915-5765 / 886-22916-0215
[Http://www.zippy.com.tw](http://www.zippy.com.tw)

APPROVED DATA SHEET

Model: 1001121082(SM1-N6H-05P0-Z)

ISSUED DATE: JUN.06.2014
APPROVED NO.: 1001121082.B
PAGE: 1/4

The undersigned guarantee of the model switches is meets the following specifications.

1.Operation Characteristics

Operating Force (OF)	:	Max.117 gf
Releasing Force (RF)	:	Min. 21 gf
Free Position (FP)	:	Max. 20.50 mm
Operating Position (OP)	:	17.1±1.1 mm
Movement Differential (MD)	:	Max.1.44 mm
Over-travel (OT)	:	Min. 0.55 mm
Pre-travel (PT)	:	Max.4.60 mm

2. Specifications

Initial Contact Resistance	:	Max. 300 mΩ . (Measured by ohm meter –Open Voltage<1VDC, Driver current -100mA) Before measure the switch contact resistance, please press the switch three times on and off.
Initial Dielectric Strength	:	500VAC(50-60HZ)/minute between contacts. 1,500VAC(50-60HZ)/minute between Live-parts and dead metal parts.
Insulation Resistance	:	Min. 100 MΩ (500 VDC/ minute) between Live-parts and dead metal parts.
Circuit Arrangement	:	SPDT (Single pole double throw)
Rating	:	6A 125/250VAC; 5A 30VDC
Service Life	:	Min. 10,000 operations.
Rating Load	:	Resistive Load.
Operating Frequency	:	10~30 operations per minute.
Safety Certificate	:	UL, cUL, ENEC15



10F, NO.50, MIN CHYUAN ROAD,
SHIN-TIEN CITY, TAIPEI COUNTY,
TAIWAN, R.O.C

TEL: 886-2-2918-8512 / 886-2-2918-0603
FAX: 886-2-2915-5765 / 886-22916-0215
[Http://www.zippy.com.tw](http://www.zippy.com.tw)

APPROVED DATA SHEET

Model: 1001121082(SM1-N6H-05P0-Z)

ISSUED DATE: JUN.06.2014
APPROVED NO.: 1001121082.B
PAGE: 2/4

3. Environments

Operating Temperature	:	-40°C ~ 125°C (with no icing)
Vibration Resistance	:	10~55Hz, displacement 0.75mm(p-p)
Shock Resistance	:	Destruction: 1,000 m/s ² {approx. 100G} max. Malfunction: 300 m/s ² {approx. 30G} max.
Soldering by hand	:	350°C maximum within 5 seconds.
Soldering bath	:	260°C maximum within 5 seconds.

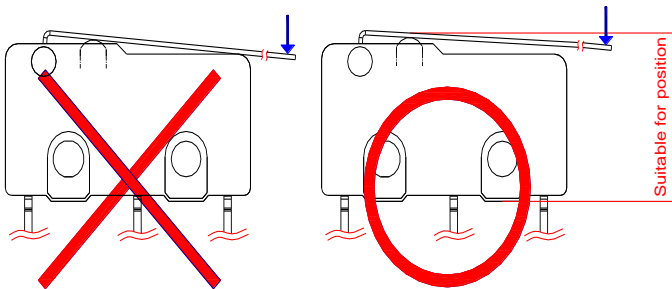

ZIPPY TECHNOLOGY CORP.

卓妍蓁

PREPARED

林佩貞

CHECKED

倪有庭

APPROVED

Dimensions drawing

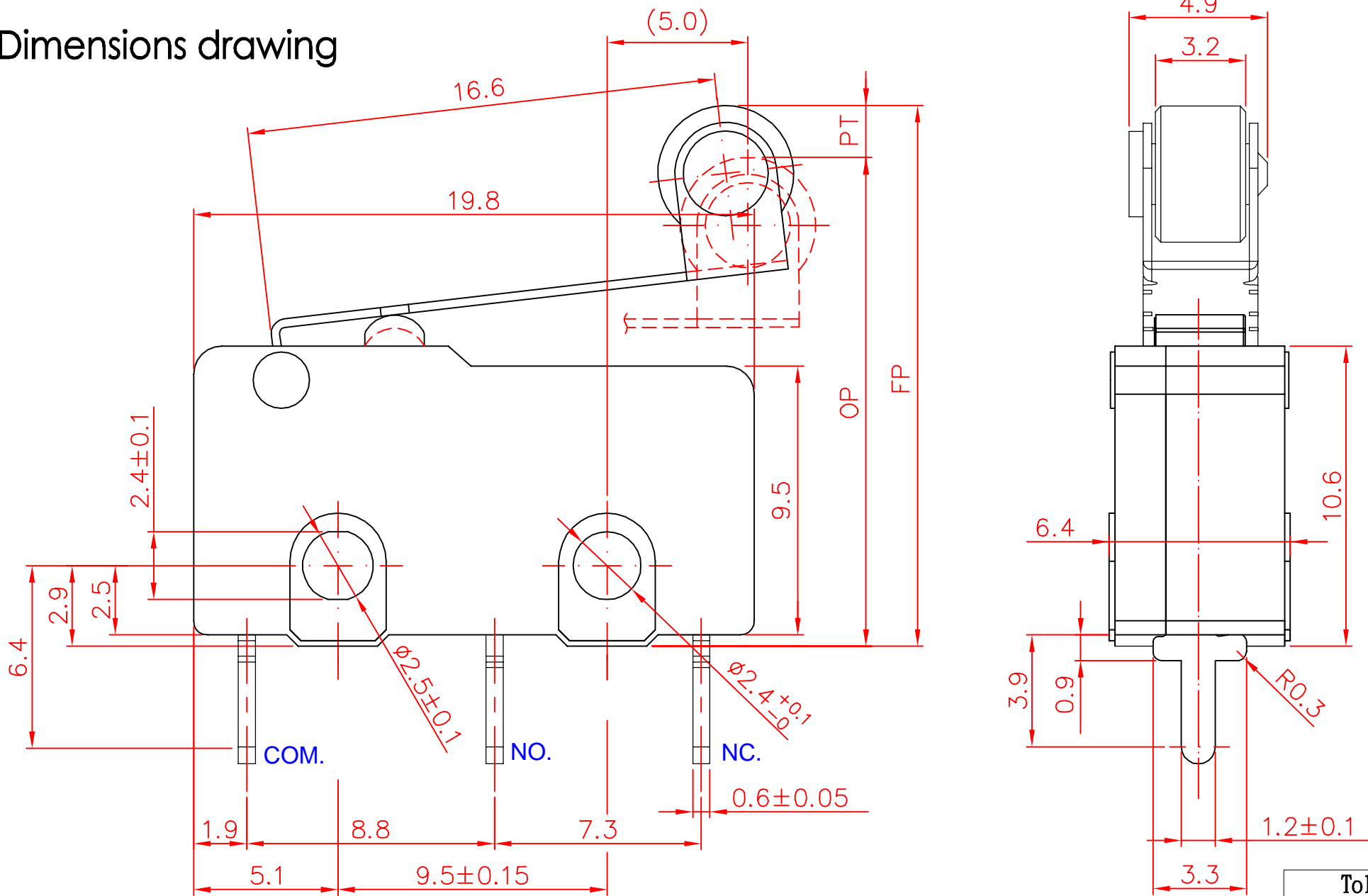

VIEW		SIZE	A4	UNIT	mm
DATE	Apr.16.2012	VER	1.3	FILE NAME	SM1-05PO
APPROVAL	李金龍	CONFIRM	張哲維	DESIGN	廖剛緯

Marking drawing

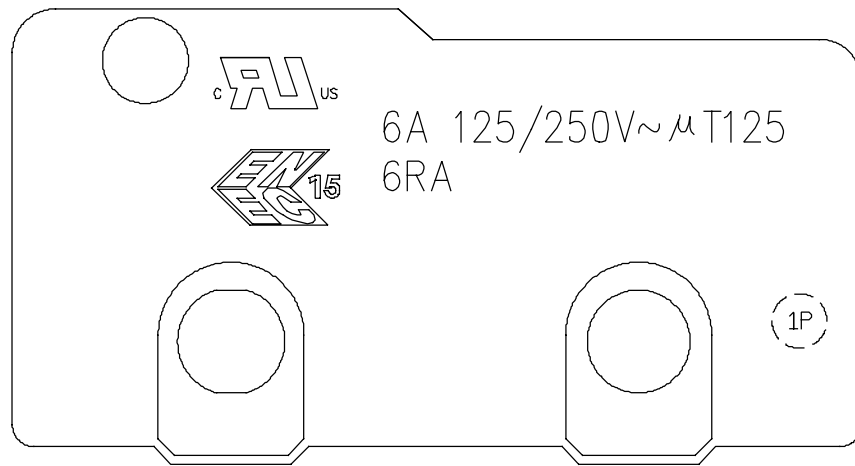

COVER

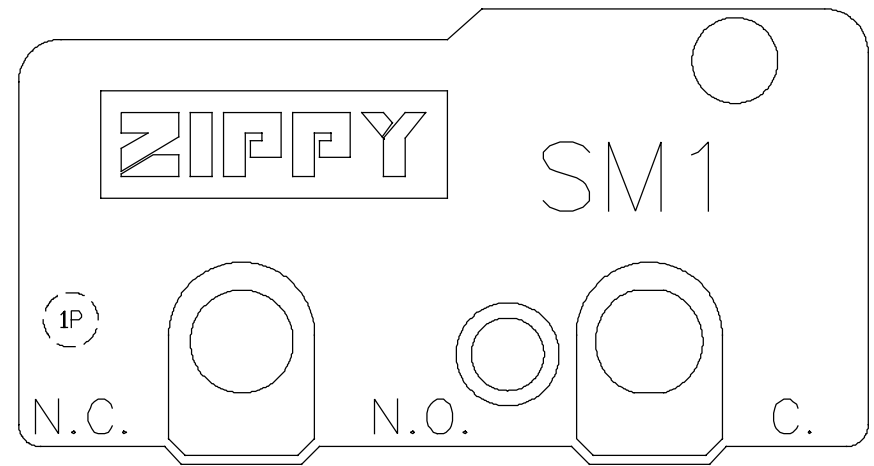

CASE

Markings are either by printing or molding

VIEW		SIZE	A4	UNIT	mm
DATE	Jul 12, 2016	VER.	1.4	FILE NAME	SM1-N6
APPROVAL	倪有庭	CONFIRM	陳維塘	DESIGN	王永輝