



ZIPPY TECHNOLOGY CORP.



10F, NO.50, MIN CHYUAN ROAD,
SHIN-TIEN CITY, TAIPEI COUNTY,
TAIWAN, R.O.C

TEL: 886-2-2918-8512 / 886-2-2918-0603
FAX: 886-2-2915-5765 / 886-22916-0215
[Http://www.zippy.com.tw](http://www.zippy.com.tw)

APPROVED DATA SHEET

Model: 1001120232(SM1-16H-02A0-Z)
=====

ISSUED DATE: NOV.12.2015
APPROVED NO.: 1001120232.B
PAGE: 1/4

The undersigned guarantee of the model switches is meets the following specifications.

1.Operation Characteristics

Operating Force (OF) : Max.107 gf
Releasing Force (RF) : Min.17 gf
Free Position (FP) : Max.14.94 mm
Operating Position (OP) : 11.4±1.3 mm
Movement Differential (MD) : Max1.67 mm
Over-travel (OT) : Min.0.48 mm
Pre-travel (PT) : Max.5.29 mm

2. Specifications

Initial Contact Resistance : Max. 300 mΩ .
(Measured by ohm meter –Open Voltage<1VDC, Driver current -100mA)
Before measure the switch contact resistance, please press the switch three times on and off.

Initial Dielectric Strength : 1,000VAC(50-60HZ)/minute between contacts.
1,500VAC(50-60HZ)/minute between Live-parts and dead metal parts.

Insulation Resistance : Min. 100 MΩ (500 VDC/ minute) between Live-parts and dead metal parts.

Circuit Arrangement : SPDT (Single pole double throw)

Rating : 16A 125/250VAC; 6(3)A 125/250VAC

Service Life : Min. 10,000 operations.

Rating Load : Resistive and Motor Load.

Operating Frequency : 10~30 operations per minute.

Safety Certificate : UL, cUL, ENEC



APPROVED DATA SHEET

Model: 1001120232(SM1-16H-02A0-Z)

ISSUED DATE: NOV.12.2015
APPROVED NO.: 1001120232.B
PAGE: 2/4

3. Environments

- Operating Temperature : -40°C ~ 125°C (with no icing)
- Vibration Resistance : 10~55Hz, displacement 0.75mm(p-p)
- Shock Resistance : Destruction: 1,000 m/s² {approx. 100G} max.
Malfunction: 300 m/s² {approx. 30G} max.

(For the pin plunger models, the vibration & shock condition apply for use at the free position and total travel position)

(For the lever models, the vibration & shock condition apply for use at the total travel position)

- Soldering by hand : 350°C maximum within 5 seconds.
- Soldering bath : 260°C maximum within 5 seconds.

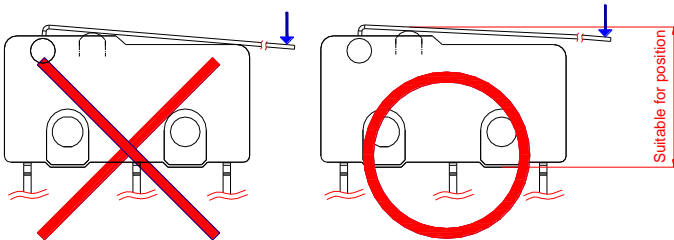

ZIPPY TECHNOLOGY CORP.

卓妍蓁

PREPARED

林佩貞

CHECKED

倪有庭

APPROVED

Dimensions drawing

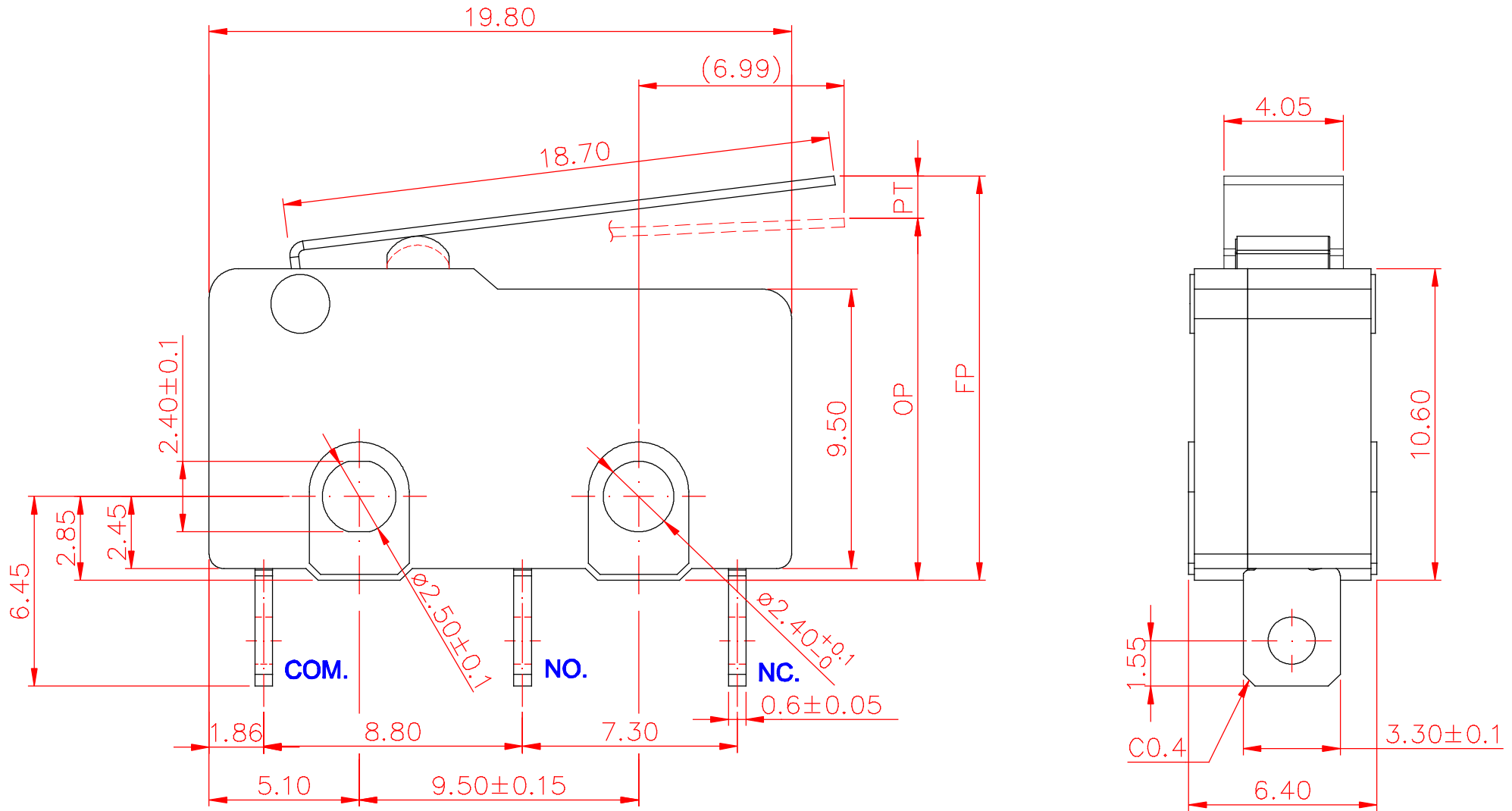

Tolerance	
X. X	± 0.2
XX. X	± 0.4

VIEW		SIZE	A4	UNIT	mm
DATE	MAY.11.2015	VER.	1.6	FILE NAME	SM1-02A0
APPROVAL	張哲維	CONFIRM	李東軒	DESIGN	林佩貞

Marking drawing

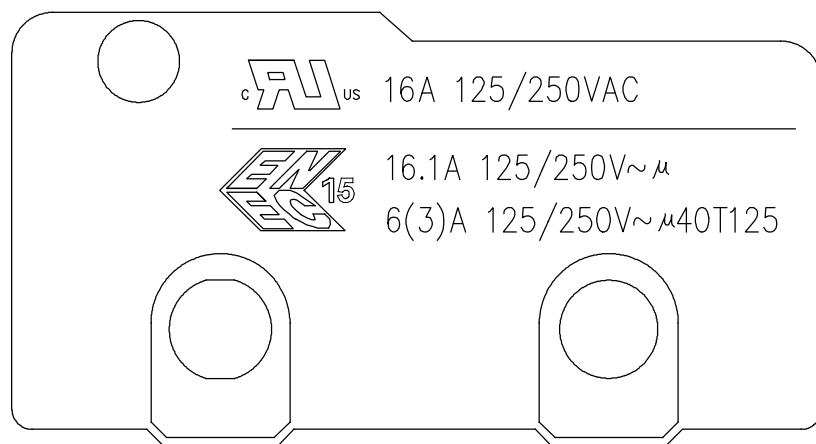

COVER

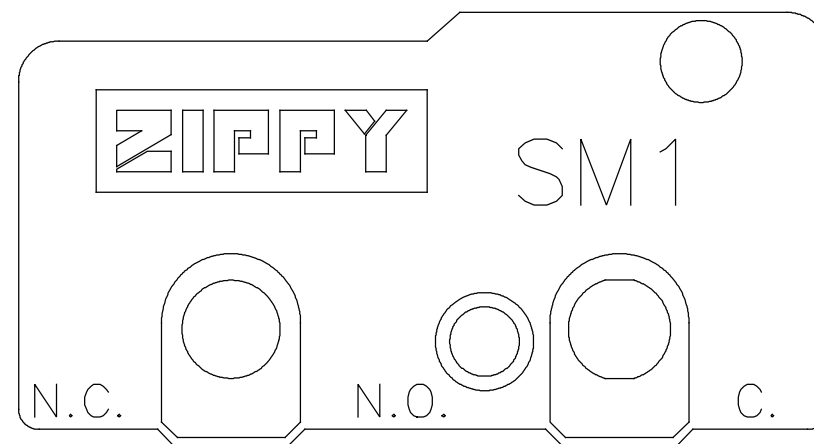

CASE

1. Markings are either by printing or molding.
2. Appearance according to dimensions drawing.

VIEW		SIZE	A4	UNIT	mm
DATE	SEP.24.2015	VER.	1.4	FILE NAME	SM1-16
APPROVAL	倪有庭	CONFIRM	王永輝	DESIGN	林佩貞