



ZIPPY TECHNOLOGY CORP.



10F, NO.50, MIN CHYUAN ROAD,
SHIN-TIEN CITY, TAIPEI COUNTY,
TAIWAN, R.O.C

TEL: 886-2-2918-8512 / 886-2-2918-0603
FAX: 886-2-2915-5765 / 886-22916-0215
[Http://www.zippy.com.tw](http://www.zippy.com.tw)

APPROVED DATA SHEET

Model: 1000140146(DW-N3S-01P0F-Z)
=====

ISSUED DATE: OCT.27.2015
APPROVED NO.: 1000140146.D
PAGE: 1/4

The undersigned guarantee of the model switches is meets the following specifications.

1.Operation Characteristics

Operating Force (OF) : Max. 195 gf
Releasing Force (RF) : Min. 55 gf
Free Position (FP) : Max. 10.7 mm
Operating Position (OP) : 7.4±0.5 mm
Movement Differential (MD) : Max. 0.5 mm
Over-travel (OT) : Min. 1.35 mm
Pre-travel (PT) : Max. 3.85 mm

2. Specifications

Initial Contact Resistance : Max. 100 mΩ .
(Measured by ohm meter –Open Voltage<1VDC, Driver current -100mA)
Before measure the switch contact resistance, please press the switch three times on and off.

Initial Dielectric Strength : 150VAC(50-60HZ)/minute between contacts.
500VAC(50-60HZ)/minute between Live-parts and dead metal parts.

Insulation Resistance : Min. 100 MΩ (500 VDC/ minute) between Live-parts and dead metal parts.

Circuit Arrangement : SPDT (Single pole double throw)

Rating and Service Life : 3A 12VDC - Min. 100,000 operations.
: 3A 125VAC - Min. 6,000 operations.

Rating Load : Resistive Load.

Operating Frequency : 10~30 operations per minute.

Safety Certificate : ENEC (3A 12VDC)

Mechanical Service Life : Min. 500,000 operations.

Operating Frequency : Max. 120 operations per minute.



10F, NO.50, MIN CHYUAN ROAD,
SHIN-TIEN CITY, TAIPEI COUNTY,
TAIWAN, R.O.C

TEL: 886-2-2918-8512 / 886-2-2918-0603
FAX: 886-2-2915-5765 / 886-22916-0215
[Http://www.zippy.com.tw](http://www.zippy.com.tw)

APPROVED DATA SHEET

Model: 1000140146(DW-N3S-01P0F-Z)

ISSUED DATE: OCT.27.2015
APPROVED NO.: 1000140146.D
PAGE: 1/4

3. Environments

Operating Temperature : -40°C ~85°C (with no icing)
Vibration Resistance : 10~55Hz, displacement 0.75mm(p-p)
Shock Resistance : Destruction: 1,000 m/s² {approx. 100G} max.
Malfunction: 300 m/s² {approx. 30G} max.

(For the pin plunger models, the vibration & shock condition apply for use at the free position and total travel position)
(For the lever models, the vibration & shock condition apply for use at the total travel position)

Soldering by hand : 300°C maximum within 5 seconds.
350°C maximum within 3 seconds.
Soldering bath : 260°C maximum within 5 seconds.

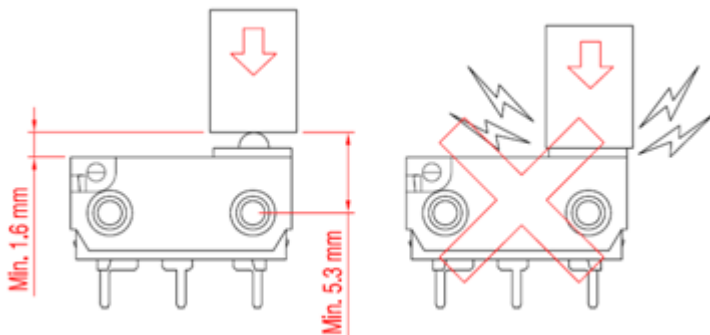

ZIPPY TECHNOLOGY CORP.

簡素玲

PREPARED

歐大揮

CHECKED

張哲維

APPROVED

Dimensions drawing

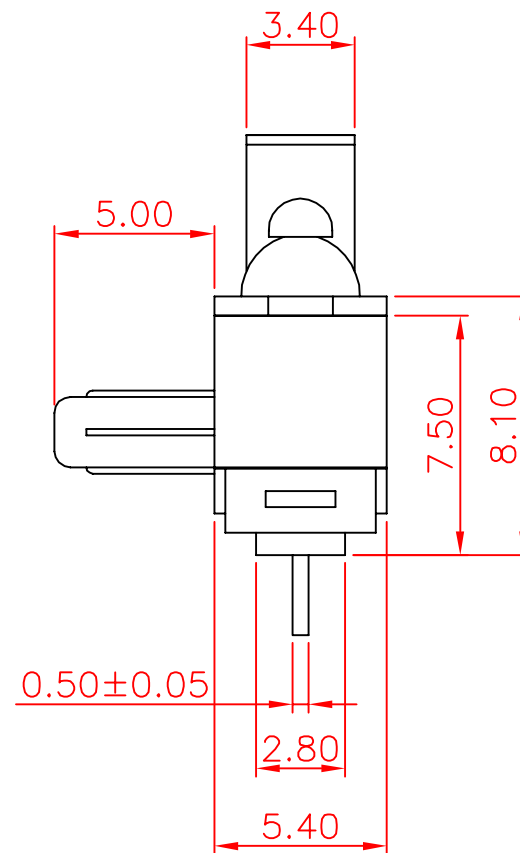
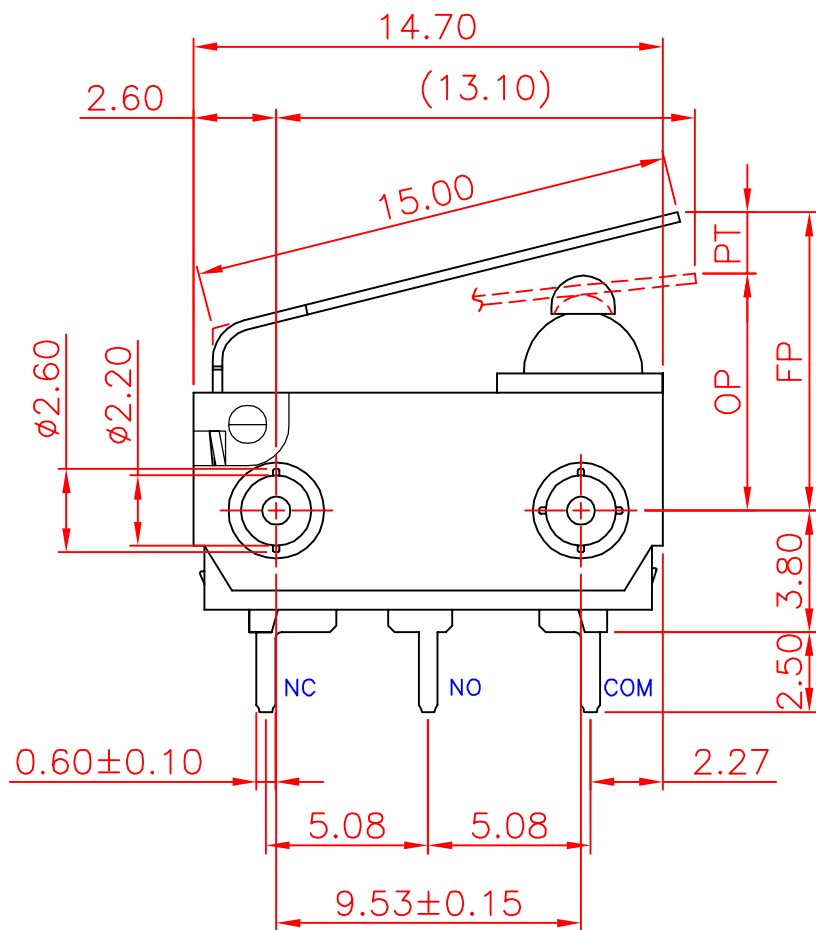

Tolerance	
X.X	±0.2
XX.X	±0.4

VIEW		SIZE	A4	UNIT	mm
DATE	DEC 27, 2011	VER.	1.4	FILE NAME	DW-01POF
APPROVAL	李金龍	CONFIRM	張哲維	DESIGN	歐大揮

Marking drawing

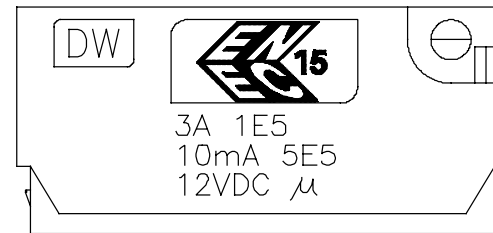
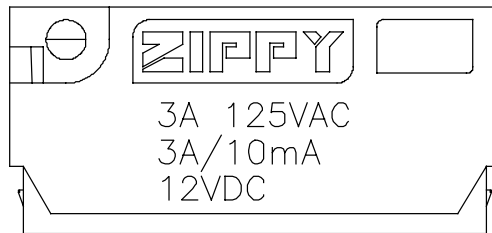

1. Marking will be random on side A or side B.
2. Markings are either by printing or molding.
3. Appearance according to dimensions drawing.

Tolerance ±0.4

VIEW		SIZE	A4	UNIT	mm
DATE	SEP.23.2015	VER.	1.2	FILE NAME	DW-03-Z
APPROVAL	張哲維	CONFIRM	黃俊嘉	DESIGN	歐大揮