



ZIPPY TECHNOLOGY CORP.



10F, NO.50, MIN CHYUAN ROAD,  
SHIN-TIEN CITY, TAIPEI COUNTY,  
TAIWAN, R.O.C

TEL: 886-2-2918-8512 / 886-2-2918-0603  
FAX: 886-2-2915-5765 / 886-22916-0215  
[Http://www.zippy.com.tw](http://www.zippy.com.tw)

### APPROVED DATA SHEET

Model: 1000140132(DW-N2S-00P0D-Z)

ISSUED DATE: 2020.01.06  
APPROVED NO.: 1000140132.F  
PAGE: 1/5

The undersigned guarantee of the model switches is meets the following specifications.

#### 1.Operation Characteristics

Operating Force (OF)	:	Max. 130 gf
Releasing Force (RF)	:	Min. 13 gf
Free Position ( FP )	:	Max. 3.65 mm
Operating Position (OP)	:	3.05±0.2 mm
Movement Differential (MD)	:	Max. 0.3 mm
Over-travel (OT)	:	Min. 0.8 mm
Pre-travel (PT)	:	Max. 0.8 mm

#### 2. Specifications

Initial Contact Resistance	:	Max. 100 mΩ . ( Measured by ohm meter –Open Voltage<1VDC, Driver current -100mA ) Before measure the switch contact resistance, please press the switch three times on and off.
Initial Dielectric Strength	:	150VAC(50-60HZ)/minute between contacts. 500VAC(50-60HZ)/minute between Live-parts and dead metal parts.
Insulation Resistance	:	Min. 100 MΩ ( 500 VDC/ minute ) between Live-parts and dead metal parts.
Circuit Arrangement	:	SPDT ( Single pole double throw )
Rating	:	10mA 12VDC
Service Life	:	Min. 500,000 operations.
Rating Load	:	Resistive Load.
Operating Frequency	:	10~30 operations per minute.
Safety Certificate	:	ENEC
Mechanical Service Life	:	Min. 500,000 operations.
Operating Frequency	:	Max. 120 operations per minute.



ZIPPY TECHNOLOGY CORP.



10F, NO.50, MIN CHYUAN ROAD,  
SHIN-TIEN CITY, TAIPEI COUNTY,  
TAIWAN, R.O.C

TEL: 886-2-2918-8512 / 886-2-2918-0603  
FAX: 886-2-2915-5765 / 886-22916-0215  
[Http://www.zippy.com.tw](http://www.zippy.com.tw)

**APPROVED DATA SHEET**

-----  
**Model: 1000140132(DW-N2S-00P0D-Z)**  
=====

ISSUED DATE: 2020.01.06  
APPROVED NO.: 1000140132.F  
PAGE: 2/4

**3. Environments**

- Operating Temperature : -40°C~85°C
- Vibration Resistance : 10~55Hz, displacement 0.75mm(p-p)
- Shock Resistance : Destruction: 1,000 m/s<sup>2</sup> {approx. 100G} max.  
Malfunction: 300 m/s<sup>2</sup> {approx. 30G} max.

( For the pin plunger models, the vibration & shock condition apply for use at the free position and total travel position )

( For the lever models, the vibration & shock condition apply for use at the total travel position )

- Soldering by hand : 300°C maximum within 5 seconds.  
350°C maximum within 3 seconds.
- Soldering bath : 260°C maximum within 5 seconds.

ZIPPY TECHNOLOGY CORP.

歐大揮

-----  
PREPARED

黃俊嘉

-----  
CHECKED

倪有庭

-----  
APPROVED

# Dimensions drawing

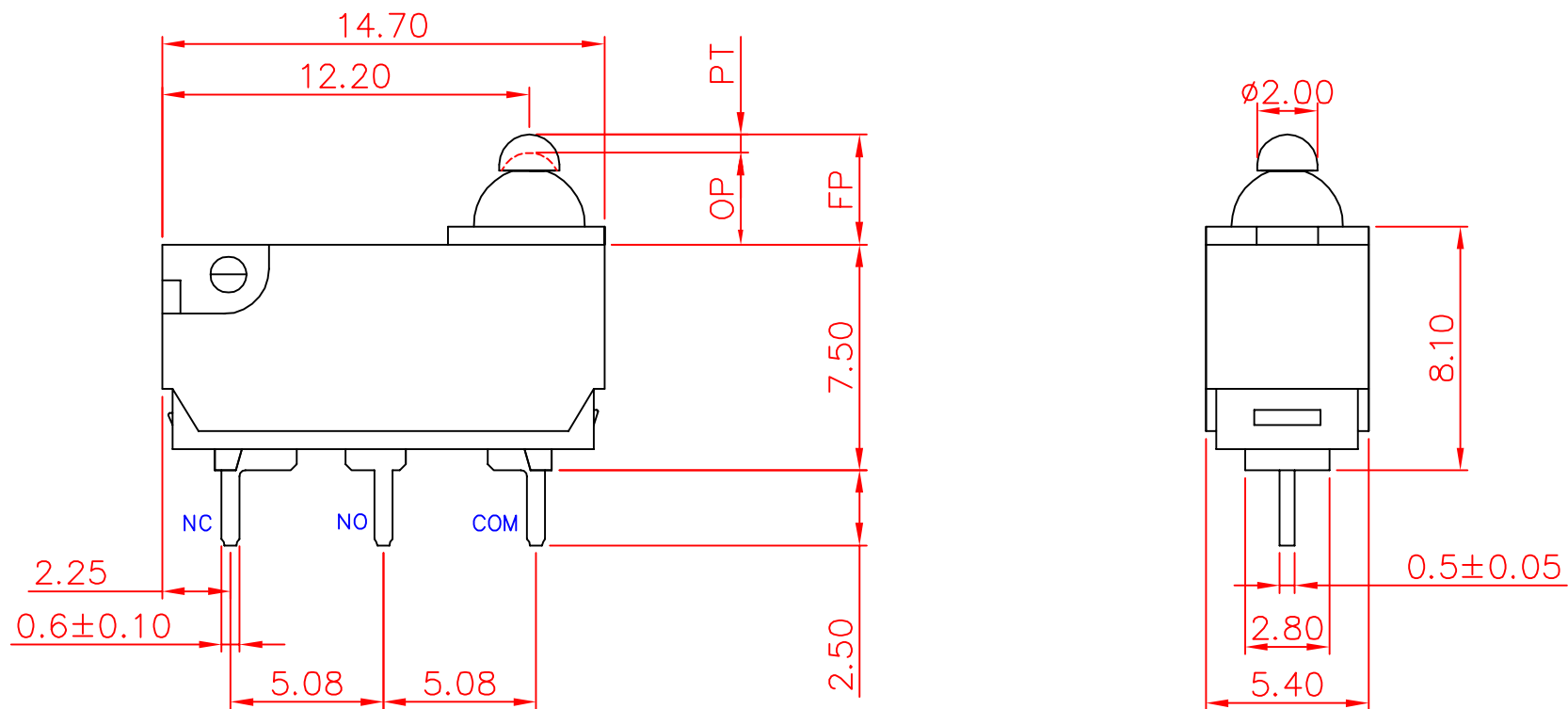

Tolerance	
X.X	$\pm 0.2$
XX.X	$\pm 0.4$

VIEW		SIZE	A4	UNIT	mm
DATE	DEC 09, 2011	VER.	1.4	FILE NAME	DW-00POD
APPROVAL	李金龍	CONFIRM	張哲維	DESIGN	歐大揮

新巨企業股份有限公司 **ZIPPY** TECHNOLOGY CORP.

# Marking drawing

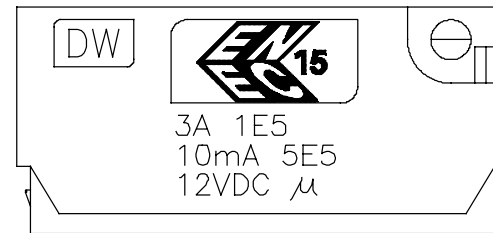
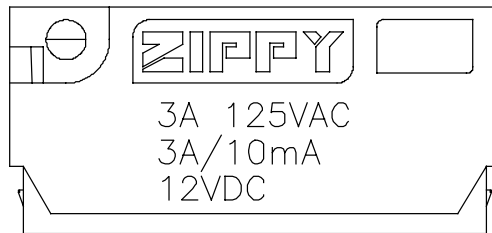

1. Marking will be random on side A or side B.
2. Markings are either by printing or molding.
3. Appearance according to dimensions drawing.

Tolerance ±0.4

VIEW		SIZE	A4	UNIT	mm
DATE	SEP.23.2015	VER.	1.2	FILE NAME	DW-03-Z
APPROVAL	張哲維	CONFIRM	黃俊嘉	DESIGN	歐大揮

## CAUTIONS:

### 注意事項

**1:** To secure the switch, please use an M3 small screw on a flat surface and tighten with plane washers or spring washers to securely mount the Switch, using a maximum torque of 0.29 N·m.

若使用定位孔型式上蓋，請使用M3小型螺絲固定在平面上，並使用平墊圈或者彈性墊圈以便安全的鎖固開關，鎖固扭力請勿超過0.29 Nm。

**2:** Do not handle the switch in a way that may cause damage to the sealed rubber & switch sealing.

使用開關時，請勿損壞開關防水矽膠罩及開關防水膠。

**3:** Wires should not be dragged.

使用帶線型式時，請注意避免拉扯線材。

**4:** To ensure the best performance of the switch, when handling/installing the switch, please do not apply uneven pressure to the direction indicated by the arrow in Figure 1. Any uneven pressure or pressure direction other than the operating direction might be harmful or damage the switch performance.

為確保開關正常運作，安裝及取用開關時，請勿直接施加壓力在圖-1中箭頭所指示的方向。如圖所示，任何不對稱的壓力或作動方向以外的壓力都不適用在開關按柄上。

**5:** Do not exceed the end position (EP) and over travel (OT). This could cause operation failure. (Figure-2)

圖示設計按壓位置，請勿超過開關下死點及超出行程，以避免開關失效。(圖2)

**6:** Avoid applying any grease/oil and chemicals on the switch rubber.

請避免沾附任何油脂或者化學物質在開關的矽膠防水罩上。

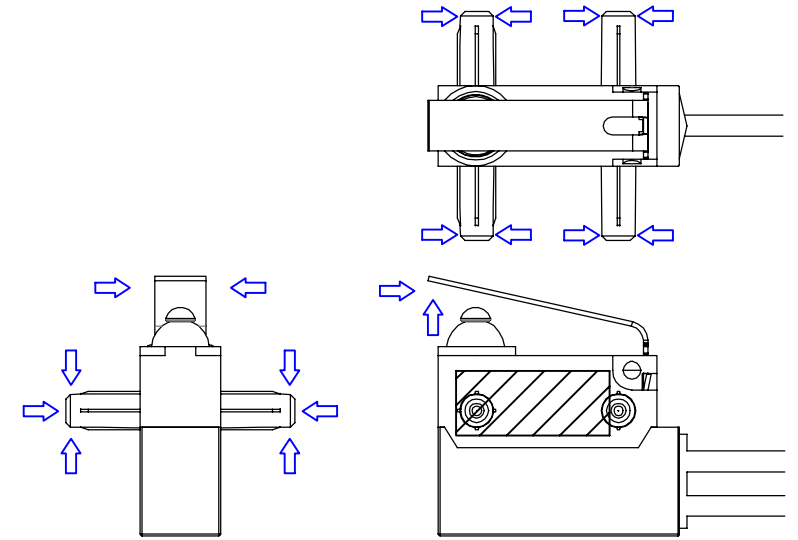

Figure-1

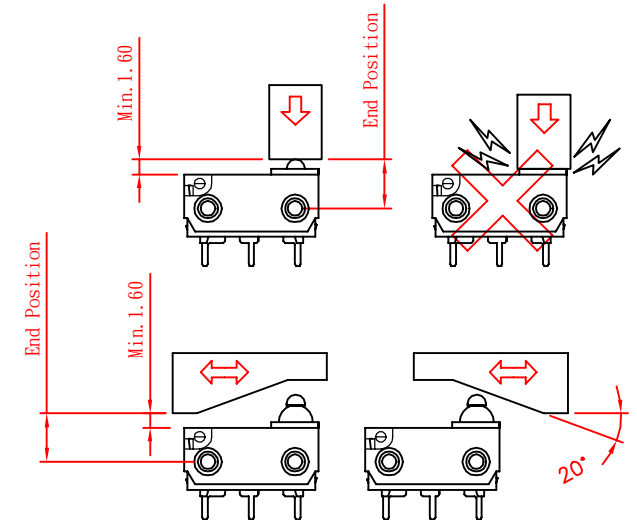

Figure-2

△	DATE	APPROVAL	DESIGN	ENGINEERING CHANGE DESCRIPTION	VIEW		SIZE	A4	UNIT	mm
新巨企業股份有限公司				ZIPPY TECHNOLOGY CORP.	DATE	2019.12.12	VER.	1.0	FILE NAME	DW-CAUTIONS
					APPROVAL	倪有庭	CONFIRM	黃俊嘉	DESIGN	歐大揮