



ZIPPY TECHNOLOGY CORP.



10F, NO.50, MIN CHYUAN ROAD,
SHIN-TIEN CITY, TAIPEI COUNTY,
TAIWAN, R.O.C

TEL: 886-2-2918-8512 / 886-2-2918-0603
FAX: 886-2-2915-5765 / 886-22916-0215
[Http://www.zippy.com.tw](http://www.zippy.com.tw)

APPROVED DATA SHEET

Model: 1001570290(DFW-03L-B02P0E-Z)

ISSUED DATE: 2019.12.30
APPROVED NO.: 1001570290.B
PAGE: 1/5

The undersigned guarantee of the model switches is meets the following specifications.

1. Operation Characteristics

Operating Force (OF)	:	Max.28 gf
Releasing Force (RF)	:	Min. 5 gf
Free Position (FP)	:	Max. 13.1 mm
Operating Position (OP)	:	9.1 ± 0.8 mm
Movement Differential (MD)	:	Max. 0.92 mm
Over-travel (OT)	:	Min. 0.7 mm
Pre-travel (PT)	:	Max. 3.5 mm

2. Specifications

Initial Contact Resistance	:	Max. 100 mΩ . Before measure the switch contact resistance, please press the switch three times on and off.
Initial Dielectric Strength	:	500VAC(50-60HZ)/minute between contacts. 1500VAC(50-60HZ)/minute between Live-parts and dead metal parts.
Insulation Resistance	:	Min. 100 MΩ (500 VDC/ minute) between Live-parts and dead metal parts.
Circuit Arrangement	:	SPDT (Single pole double throw)
Rating	:	3A 125/250VAC ; 3A 24VDC
Service Life	:	Min. 10,000 operations
Rating Load	:	Resistive Load
Operating Frequency	:	10~30 operations per minute
Safety Certificate	:	UL, cUL, ENEC
Mechanical Service Life	:	Min. 1,000,000 operations.
Operating Frequency	:	Max. 120 operations per minute
Operating application of the switch	:	Set the switch pushing distance from 60% to 90% of the specified OT value.
Protection	:	IP67 with enclosure not include bare terminal.



ZIPPY TECHNOLOGY CORP.



10F, NO.50, MIN CHYUAN ROAD,
SHIN-TIEN CITY, TAIPEI COUNTY,
TAIWAN, R.O.C

TEL: 886-2-2918-8512 / 886-2-2918-0603
FAX: 886-2-2915-5765 / 886-22916-0215
[Http://www.zippy.com.tw](http://www.zippy.com.tw)

APPROVED DATA SHEET

Model: 1001570290(DFW-03L-B02P0E-Z)

ISSUED DATE: 2019.12.30
APPROVED NO.: 1001570290.B
PAGE: 2/5

3. Environments

- Operating Temperature : -40°C ~ 85°C(with no icing)
- Vibration Resistance : 10~55Hz, displacement 0.75mm(p-p)
- Shock Resistance : Destruction: 1,000 m/s² {approx. 100G} max.
Malfunction: 300 m/s² {approx. 30G} max.

(For the pin plunger models, the vibration & shock condition apply for use at the free position and total travel position)

(For the lever models, the vibration & shock condition apply for use at the total travel position)

- Soldering by hand : 260°C maximum within 5 seconds.
300°C maximum within 3 seconds.
- Soldering bath : 260°C maximum within 5 seconds. (PCB thickness more than Min 1.6 mm.)

ZIPPY TECHNOLOGY CORP.

卓妍蓁

PREPARED

林佩貞

CHECKED

倪有庭

APPROVED

Dimensions drawing

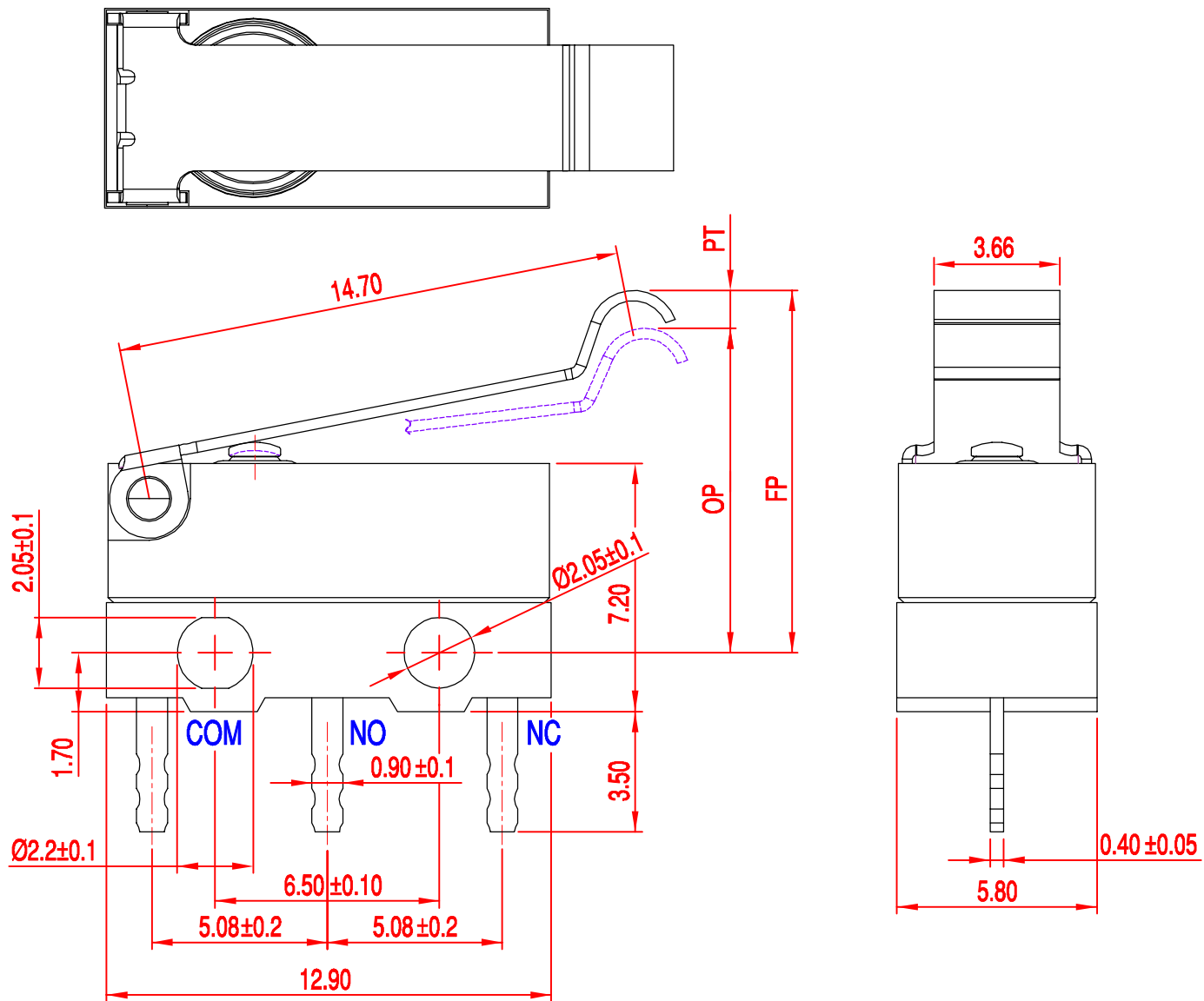

Tolerance	
X. X	± 0.2
XX. X	± 0.4

△	DATE	APPROVAL	DESIGN	ENGINEERING CHANGE DESCRIPTION
新巨企業股份有限公司				ZIPPY TECHNOLOGY CORP.

VIEW		SIZE	A4	UNIT	mm
DATE	NOV-26-2012	VER.	1.0	FILE NAME	DFW-B02POE
APPROVAL	李金龍	CONFIRM	張哲維	DESIGN	倪有庭

Marking drawing

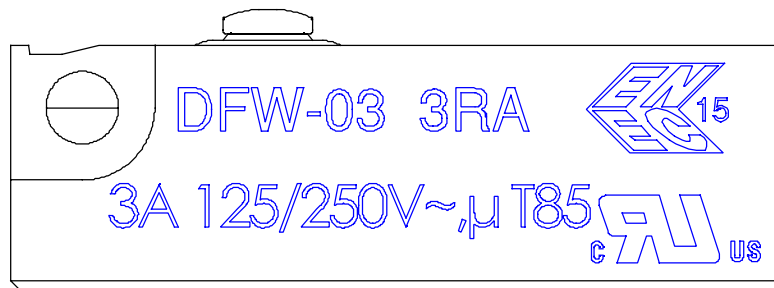
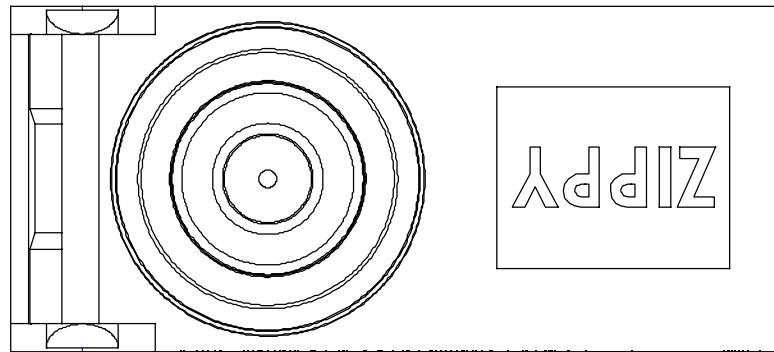

A

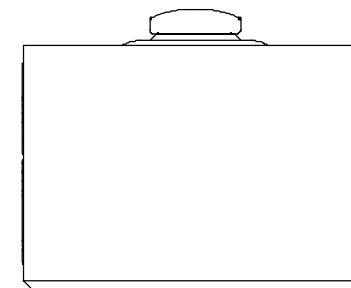

B

Marking will be random on side A or side B
 Markings are either by printing or molding

新巨企業股份有限公司

ZIPPY TECHNOLOGY CORP.

VIEW		SIZE	A4	UNIT	mm
DATE	DEC-10-2014	VER.	1.3	FILE NAME	DFW-03
APPROVAL	倪有庭	CONFIRM	王永輝	DESIGN	李東軒

CAUTIONS:

注意事項

1: To secure the switch, please use an M2 small screw on a flat surface and tighten with plane washers or spring washers to securely mount the Switch, using a maximum torque of 0.1 N·m.

若使用定位孔型式上蓋，請使用M2小型螺絲固定在平面上，並使用平墊圈或者彈性墊圈以便安全的鎖固開關，鎖固扭力請勿超過0.1 Nm。

2: Do not handle the switch in a way that may cause damage to the sealed rubber & switch sealing.

使用開關時，請勿損壞開關防水矽膠罩及開關防水膠。

3: Wires should not be dragged.

使用帶線型式時，請注意避免拉扯線材。

4: To ensure the best performance of the switch, when handling/installing the switch, please do not apply uneven pressure to the direction indicated by the arrow in Figure 1. Any uneven pressure or pressure direction other than the operating direction might be harmful or damage the switch performance.

為確保開關正常運作，安裝及取用開關時，請勿直接施加壓力在圖-1中箭頭所指示的方向。如圖所示，任何不對稱的壓力或作動方向以外的壓力都不適用在開關按柄上。

5: Do not exceed the end position (EP) and over travel (OT). This could cause operation failure.

圖示設計按壓位置，請勿超過開關下死點及超出行程，以避免開關失效。

6: Avoid applying any grease/oil and chemicals on the switch rubber.

請避免沾附任何油脂或者化學物質在開關的矽膠防水罩上。

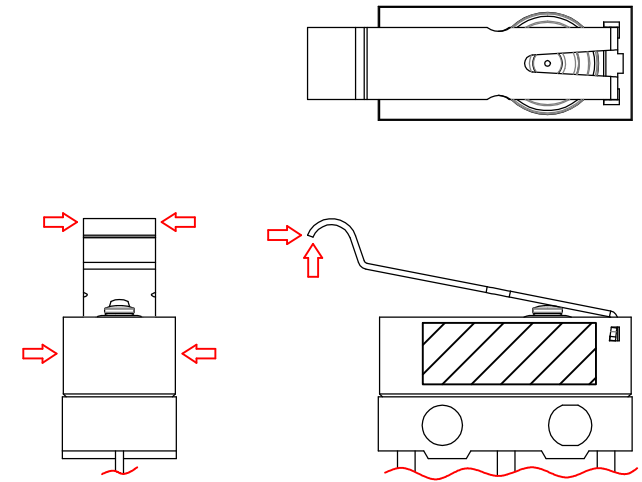
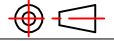

Figure-1

VIEW		SIZE	A4	UNIT	mm
DATE	2019.12.16	VER.	1.0	FILE NAME	DFW-CAUTIONS
APPROVAL	倪有庭	CONFIRM	王永輝	DESIGN	林佩貞