



ZIPPY TECHNOLOGY CORP.



10F, NO.50, MIN CHYUAN ROAD,  
SHIN-TIEN CITY, TAIPEI COUNTY,  
TAIWAN, R.O.C

TEL: 886-2-2918-8512 / 886-2-2918-0603  
FAX: 886-2-2915-5765 / 886-22916-0215  
[Http://www.zippy.com.tw](http://www.zippy.com.tw)

### APPROVED DATA SHEET

**Model: 1001530155(DF3-05S0-02P0B0-Z)**

ISSUED DATE: MAR.21.2018  
APPROVED NO.: 1001530155.C  
PAGE: 1/4

The undersigned guarantee of the model switches is meets the following specifications.

#### 1. Operation Characteristics

Operating Force (OF)	:	Max. 43 gf
Releasing Force (RF)	:	Min. 7 gf
Free Position (FP)	:	Max. 14.2 mm
Operating Position (OP)	:	10.2 ± 0.8 mm
Movement Differential (MD)	:	Max. 0.92 mm
Over-travel (OT)	:	Min. 0.7 mm
Pre-travel (PT)	:	Max. 3.5 mm

#### 2. Specifications

Initial Contact Resistance	:	Max. 100 mΩ . (Measured by ohm meter –Open Voltage<1VDC, Driver current -100mA) Before measure the switch contact resistance, please press the switch three times on and off.
Initial Dielectric Strength	:	500VAC(50-60HZ)/minute between contacts. 1500VAC(50-60HZ)/minute between Live-parts and dead metal parts.
Insulation Resistance	:	Min. 100 MΩ ( 500 VDC/ minute ) between Live-parts and dead metal parts.
Circuit Arrangement	:	SPDT ( Single pole double throw )
Rating	:	5A 125/250VAC , 3A 24VDC
Service Life	:	Min.10,000 operations
Rating Load	:	Resistive Load
Operating Frequency	:	10~30 operations per minute
Safety Certificate	:	UL, cUL, ENEC
Mechanical Service Life	:	Min. 5,000,000 operations.
Operating Frequency	:	Max. 120 operations per minute
Operating application of the switch	:	Set the switch pushing distance from 60% to 90% of the specified OT value.



ZIPPY TECHNOLOGY CORP.



10F, NO.50, MIN CHYUAN ROAD,  
SHIN-TIEN CITY, TAIPEI COUNTY,  
TAIWAN, R.O.C

TEL: 886-2-2918-8512 / 886-2-2918-0603  
FAX: 886-2-2915-5765 / 886-22916-0215  
[Http://www.zippy.com.tw](http://www.zippy.com.tw)

**APPROVED DATA SHEET**

**Model: 1001530155(DF3-05S0-02P0B0-Z)**

ISSUED DATE: MAR.21.2018  
APPROVED NO.: 1001530155.C  
PAGE: 2/4

**3. Environments**

- Operating Temperature : -40°C ~ 85°C (with no icing)
- Vibration Resistance : 10~55Hz, displacement 0.75mm(p-p)
- Shock Resistance : Destruction: 1,000 m/s<sup>2</sup> {approx. 100G} max.  
Malfunction: 300 m/s<sup>2</sup> {approx. 30G} max.

( For the pin plunger models, the vibration & shock condition apply for use at the free position and total travel position )

( For the lever models, the vibration & shock condition apply for use at the total travel position )

- Soldering by hand : 260°C maximum within 5 seconds.  
300°C maximum within 3 seconds.
- Soldering bath : 260°C maximum within 5 seconds. (PCB thickness more than Min 1.6 mm.)

ZIPPY TECHNOLOGY CORP.

黃玉燕

PREPARED

林佩貞

CHECKED

倪有庭

APPROVED

# Dimensions drawing

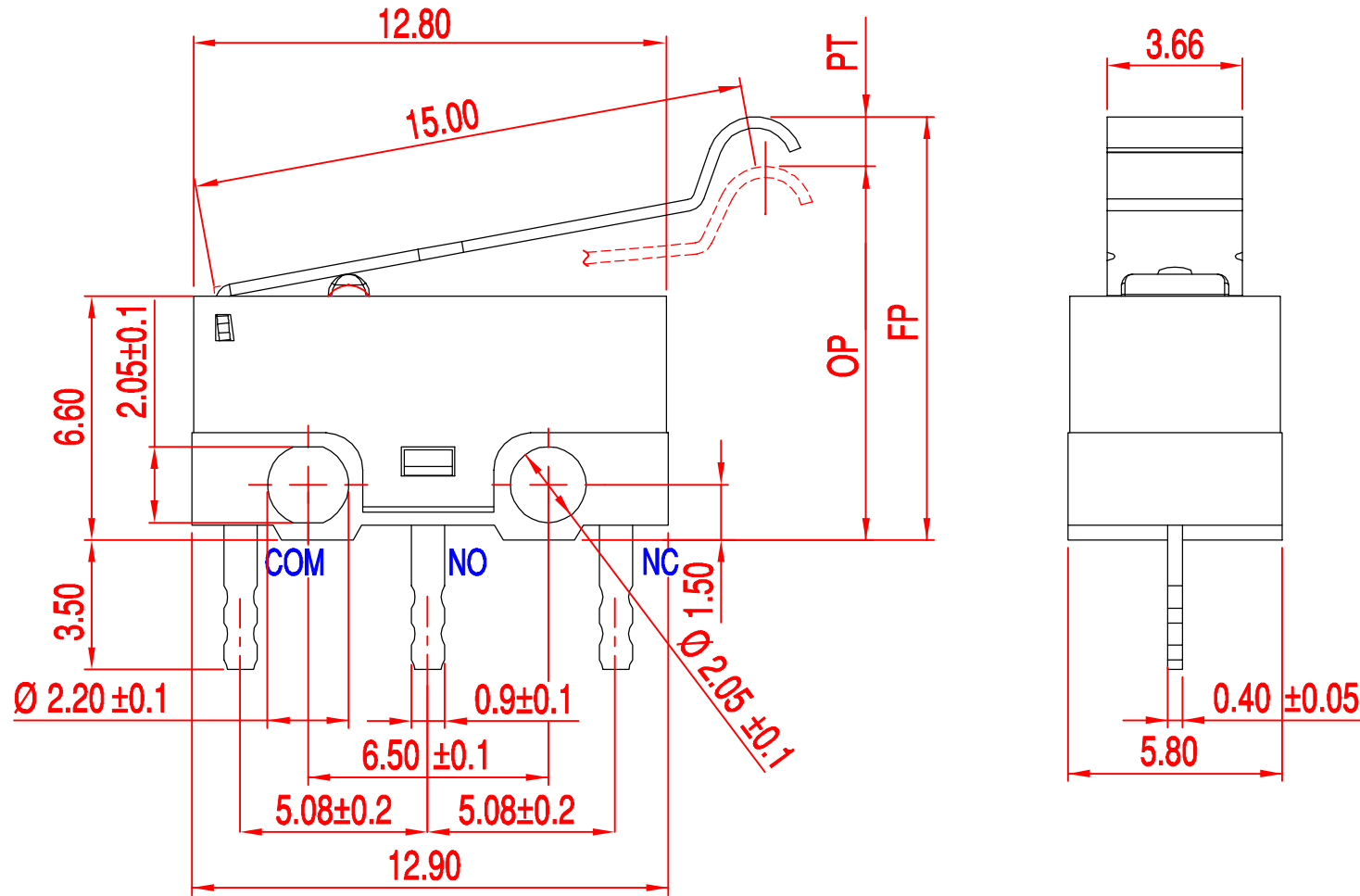
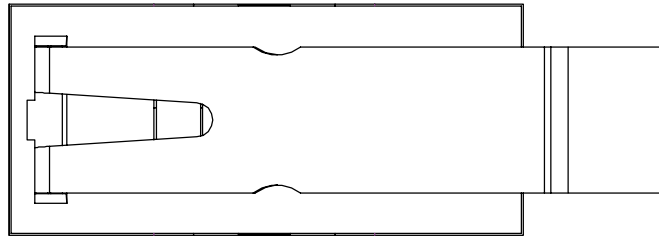

Tolerance	
X. X	± 0.2
XX. X	± 0.4

△	DATE	APPROVAL	DESIGN	ENGINEERING CHANGE DESCRIPTION
---	------	----------	--------	--------------------------------

VIEW		SIZE	A4	UNIT	mm
DATE	FEB-02-2012	VER.	1.0	FILE NAME	DF3-02P0B0
APPROVAL	李金龍	CONFIRM	張哲維	DESIGN	倪有庭

新巨企業股份有限公司

**ZIPPY** TECHNOLOGY CORP.

# Marking drawing

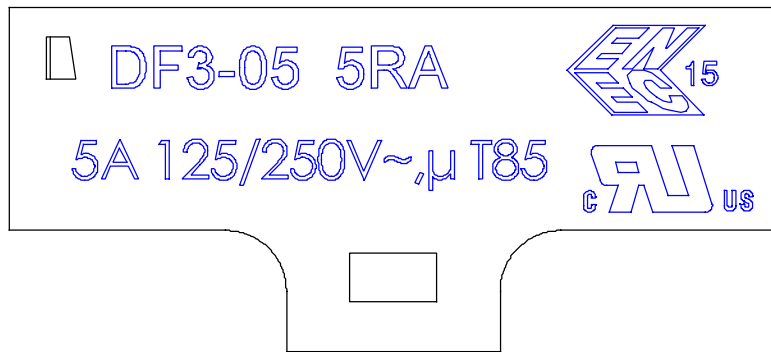
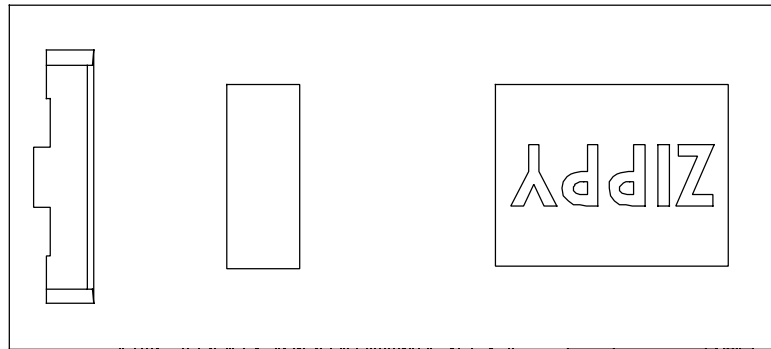

A

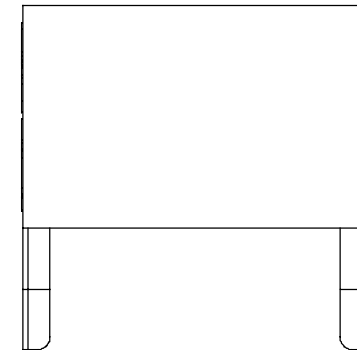

B

Marking will be random on side A or side B  
 Markings are either by printing or molding

VIEW		SIZE	A4	UNIT	mm
DATE	JAN-07-2015	VER.	1.5	FILE NAME	DF3-05
APPROVAL	倪有庭	CONFIRM	林佩貞	DESIGN	李東軒