



ZIPPY TECHNOLOGY CORP.



10F, NO.50, MIN CHYUAN ROAD,
SHIN-TIEN CITY, TAIPEI COUNTY,
TAIWAN, R.O.C

TEL: 886-2-2918-8512 / 886-2-2918-0603
FAX: 886-2-2915-5765 / 886-22916-0215
[Http://www.zippy.com.tw](http://www.zippy.com.tw)

APPROVED DATA SHEET

Model: 1000100130(DF-P1L-0P-Z)
=====

Available for the model that mouse has stoppers added more than Min. 0.1mm

ISSUED DATE: JUN.27.2013
APPROVED NO.: 1000100130.E
PAGE: 1/4

The undersigned guarantee of the model switches is meets the following specifications.

1.Operation Characteristics

Operating Force (OF) : Max.80 gf
Releasing Force (RF) : Min.21 gf
Free Position (FP) : Max. 7.35 mm
Operating Position (OP) : 7.0 ± 0.2 mm
Movement Differential (MD) : Max. 0.12 mm
Over-travel (OT) : Min. 0.2 mm
Pre-travel (PT) : Max. 0.62 mm

2. Specifications

Initial Contact Resistance : Max. 100 mΩ . (Initial) (Measured by ohm meter –Open Voltage<1VDC, Driver current -100mA)
Before measure the switch contact resistance, please press the switch three times on and off.

Initial Dielectric Strength : 1,000VAC(50-60HZ)/minute between contacts.
1,500VAC(50-60HZ)/minute between Live-parts and dead metal parts.

Insulation Resistance : Min. 100 MΩ (500 VDC/ minute) between Live-parts and dead metal parts.

Circuit Arrangement : SPDT (Single pole double throw)

Rating : 0.1A 30VDC; 0.1A 125 VAC

Service Life : Min. 1,000,000operations

Rating Load : Resistive Load

Operating Frequency : 120 operations per minute.

Mechanical Service Life : Min. 1,000,000 operations.

Operating Frequency : Max. 120 operations per minute.



ZIPPY TECHNOLOGY CORP.



10F, NO.50, MIN CHYUAN ROAD,
SHIN-TIEN CITY, TAIPEI COUNTY,
TAIWAN, R.O.C

TEL: 886-2-2918-8512 / 886-2-2918-0603
FAX: 886-2-2915-5765 / 886-22916-0215
[Http://www.zippy.com.tw](http://www.zippy.com.tw)

APPROVED DATA SHEET

Model: 1000100130(DF-P1L-0P-Z)
=====

Available for the model that mouse has stoppers added more than Min. 0.1mm

ISSUED DATE: JUN.27.2013
APPROVED NO.: 1000100130.E
PAGE: 2/4

3. Environments

- Operating Temperature : -40°C ~ 85°C(With no icing)
- Vibration Resistance : 10~55Hz, displacement 0.75mm(p-p)
- Shock Resistance : Destruction: 1,000 m/s² {approx. 100G} max.
Malfunction: 300 m/s² {approx. 30G} max.
- Soldering by hand : 260°C maximum within 5 seconds.
300°C maximum within 3 seconds.
- Soldering bath : 260°C maximum within 5 seconds. (PCB thickness more than Min 1.6 mm.)

ZIPPY TECHNOLOGY CORP.

黃玉燕

PREPARED

方鼎杰

CHECKED

張哲維

APPROVED

Dimensions drawing

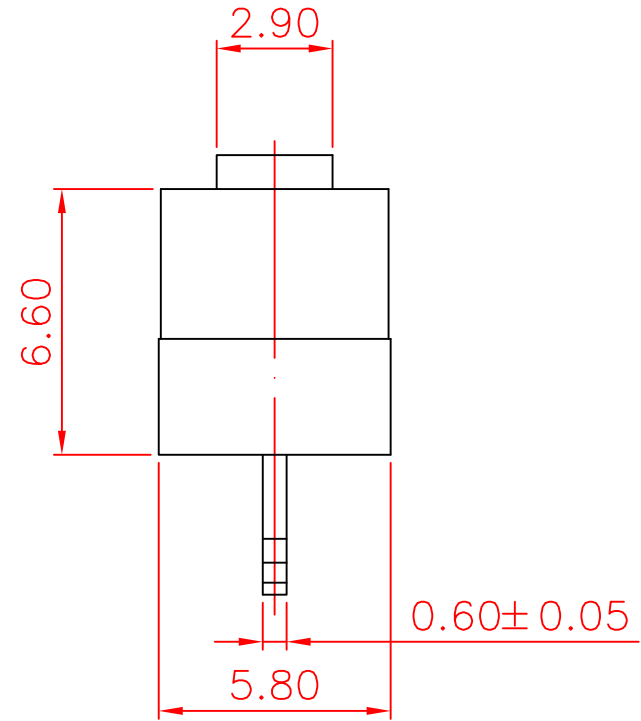
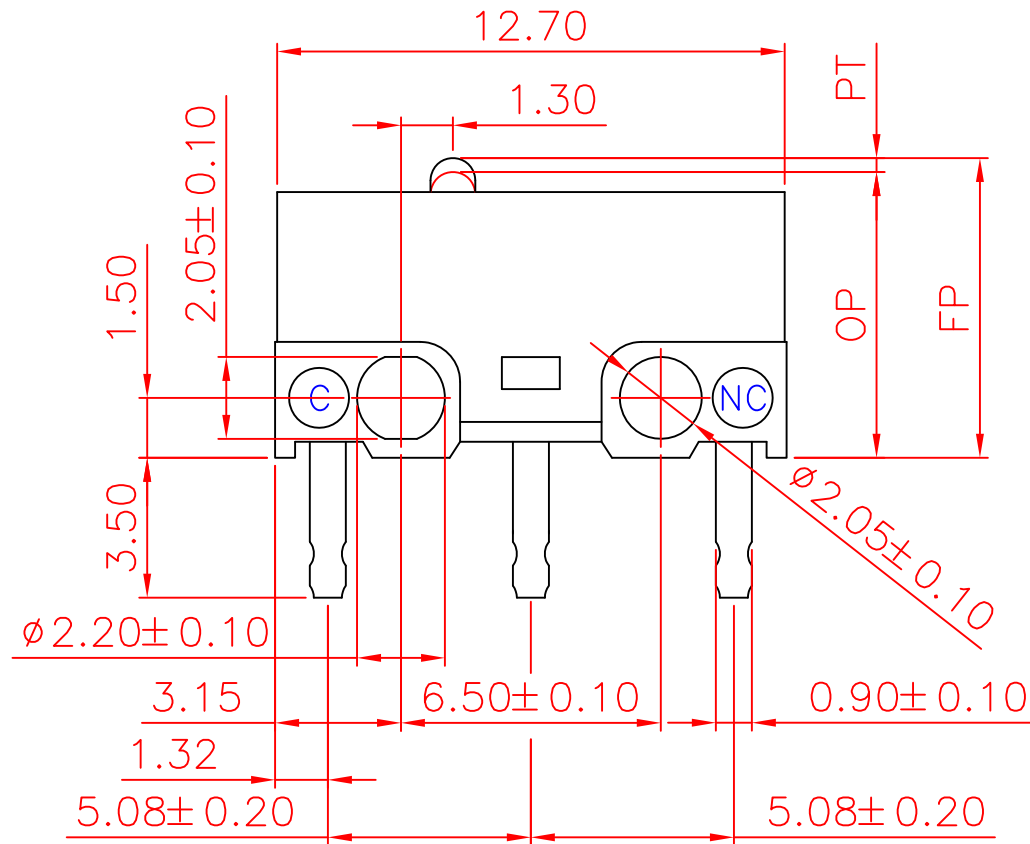
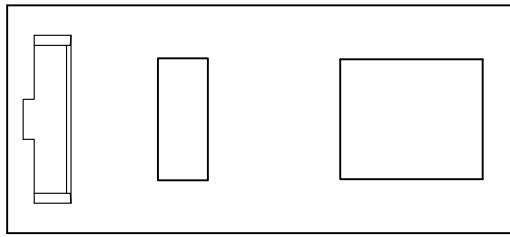

Tolerance	
X.X	± 0.2
XX.X	± 0.4

VIEW		SIZE	A4	UNIT	mm
DATE	SEP.20.2010	VER.	1.6	FILE NAME	DF-00PO
APPROVAL	李金龍	CONFIRM	張哲維	DESIGN	方鼎杰

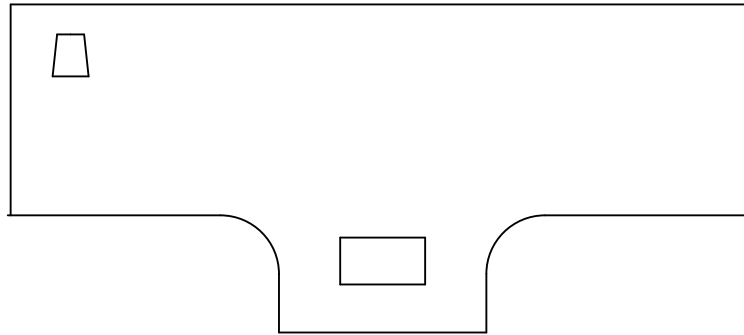
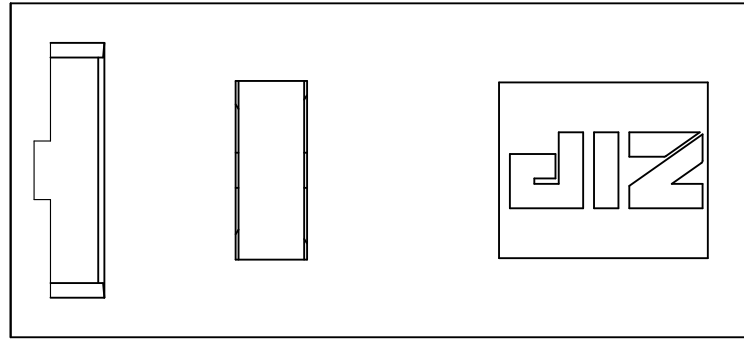

Markings are either by printing or molding

VIEW		SIZE	A4	UNIT	mm
DATE	JUL.16.2014	VER.	1.3	FILE NAME	DF-P1
APPROVAL	沈俊榮	CONFIRM	陳立業	DESIGN	張立人