



ZIPPY TECHNOLOGY CORP.



10F, NO.50, MIN CHYUAN ROAD,
SHIN-TIEN CITY, TAIPEI COUNTY,
TAIWAN, R.O.C

TEL: 886-2-2918-8512 / 886-2-2918-0603
FAX: 886-2-2915-5765 / 886-22916-0215
[Http://www.zippy.com.tw](http://www.zippy.com.tw)

APPROVED DATA SHEET

Model: 1000100396(DF-03S-8P-Z)
=====

ISSUED DATE: NOV.07.2015
APPROVED NO.: 1000100396.D
PAGE: 1/4

The undersigned guarantee of the model switches is meets the following specifications.

1. Operation Characteristics

Operating Force (OF) : Max. 54 gf
Releasing Force (RF) : Min. 9 gf
Free Position (FP) : Max. 11.2 mm
Operating Position (OP) : 8.17±0.8 mm
Movement Differential (MD) : Max. 0.7 mm
Over-travel (OT) : Min. 0.6 mm
Pre-travel (PT) : Max. 2.8 mm

2. Specifications

Initial Contact Resistance : Max. 100 mΩ .
(Measured by ohm meter –Open Voltage<1VDC, Driver current -100mA)
Before measure the switch contact resistance, please press the switch three times on and off.

Initial Dielectric Strength : 1,000VAC(50-60HZ)/minute between contacts.
1,500VAC(50-60HZ)/minute between Live-parts and dead metal parts.

Insulation Resistance : Min. 100 MΩ (500 VDC/ minute) between Live-parts and dead metal parts.

Circuit Arrangement : SPDT (Single pole double throw)

Rating : 3A 125VAC; 3A 24VDC

Service Life : Min. 10,000 operations

Rating Load : Resistive Load

Operating Frequency : 10~30 operations per minute

Safety Certificate : UL, cUL, ENEC

Mechanical Service Life : Min. 1,000,000 operations.

Operating Frequency : Max. 120 operations per minute.

Operating application of the switch : Set the switch pushing distance from 60% to 90% of the specified OT value.



ZIPPY TECHNOLOGY CORP.



10F, NO.50, MIN CHYUAN ROAD,
SHIN-TIEN CITY, TAIPEI COUNTY,
TAIWAN, R.O.C

TEL: 886-2-2918-8512 / 886-2-2918-0603
FAX: 886-2-2915-5765 / 886-22916-0215
[Http://www.zippy.com.tw](http://www.zippy.com.tw)

APPROVED DATA SHEET

Model: 1000100396(DF-03S-8P-Z)
=====

ISSUED DATE: NOV.07.2015
APPROVED NO.: 1000100396.D
PAGE: 2/4

3. Environments

- Operating Temperature : -40°C ~ 85°C (with no icing)
- Vibration Resistance : 10~55Hz, displacement 0.75mm(p-p)
- Shock Resistance : Destruction: 1,000 m/s² {approx. 100G} max.
Malfunction: 300 m/s² {approx. 30G} max.
- Soldering by hand : 260°C maximum within 5 seconds.
300°C maximum within 3 seconds.
- Soldering bath : 260°C maximum within 5 seconds. (PCB thickness more than Min 1.6 mm.)

ZIPPY TECHNOLOGY CORP.

簡素玲

PREPARED

方鼎杰

CHECKED

張哲維

APPROVED

Dimensions drawing

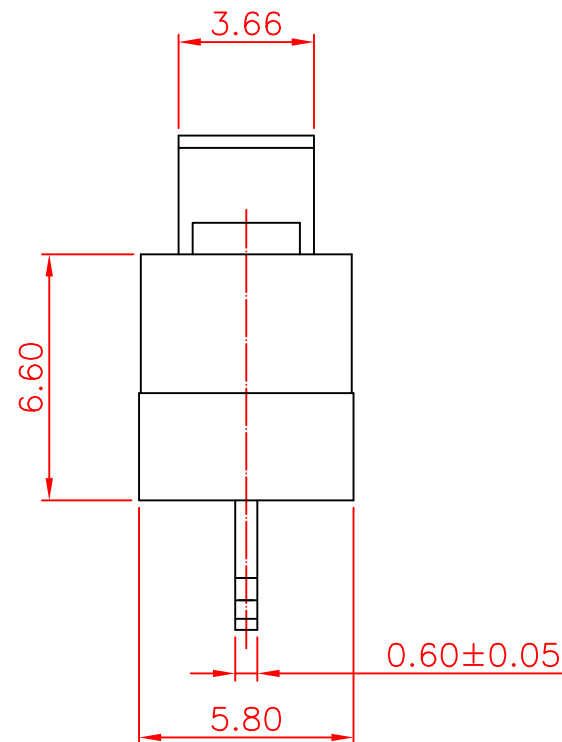
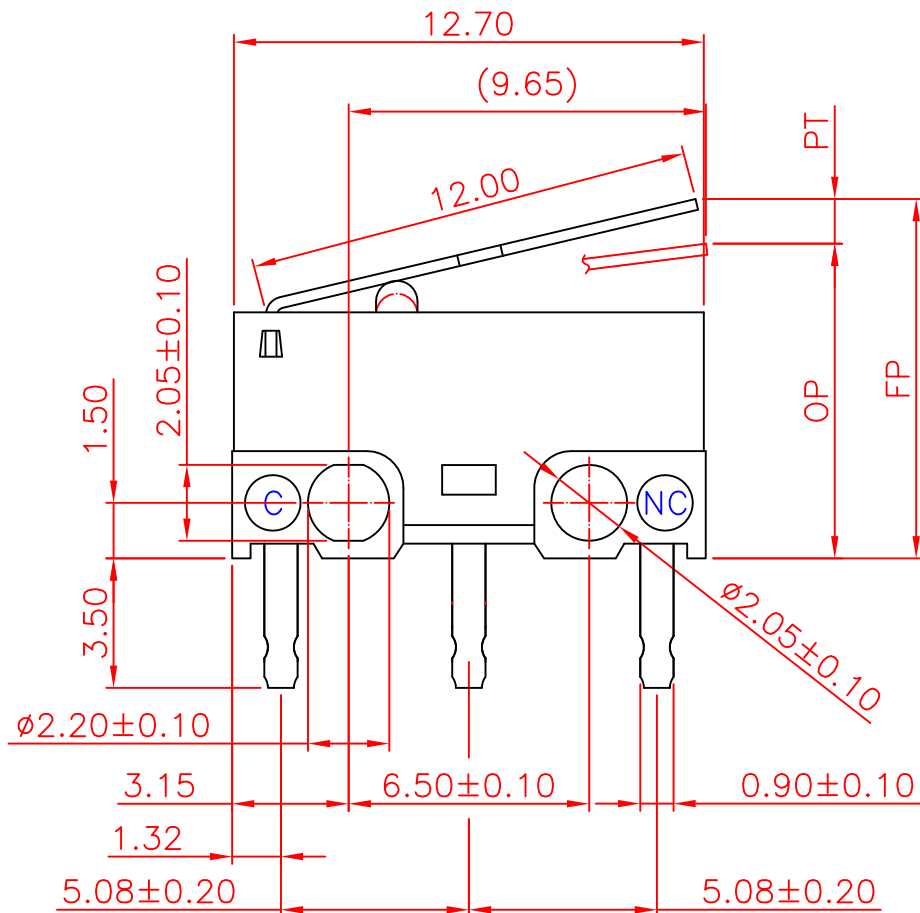
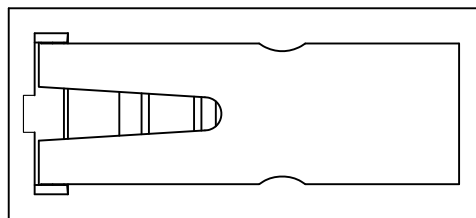

Tolerance	
X.X	± 0.2
XX.X	± 0.4

VIEW		SIZE	A4	UNIT	mm
DATE	OCT.21.2010	VER.	1.3	FILE NAME	DF-08P0
APPROVAL	李金龍	CONFIRM	張哲維	DESIGN	謝佩君

Marking drawing

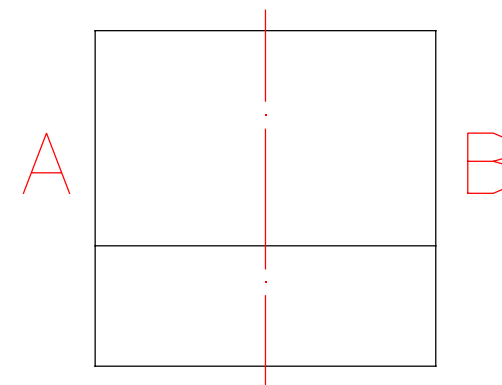
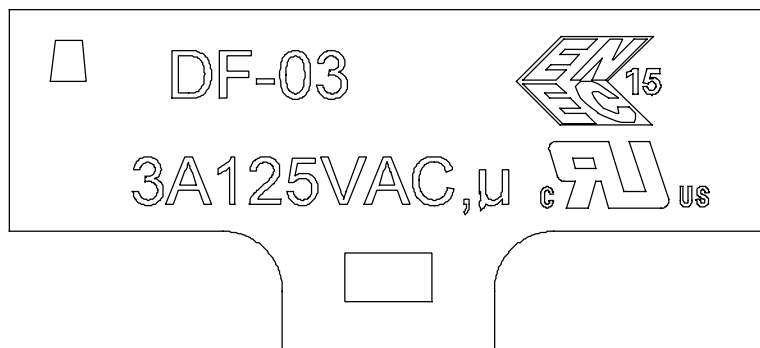
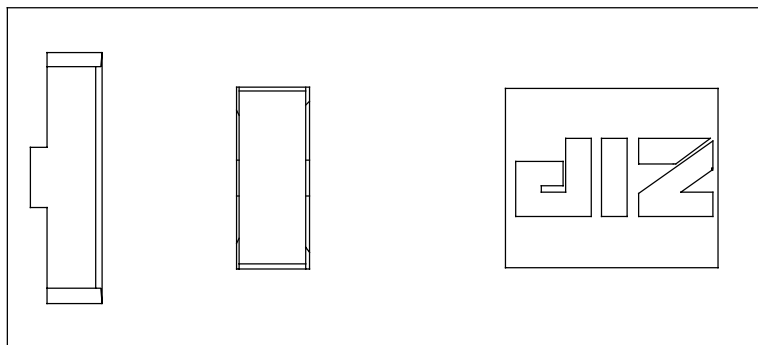

1. Marking will be random on side A or side B.
2. Markings are either by printing or molding.
3. Appearance according to dimensions drawing.

VIEW		SIZE	A4	UNIT	mm
DATE	SEP.22.2015	VER.	1.9	FILE NAME	DF-03
APPROVAL	張哲維	CONFIRM	歐大揮	DESIGN	簡永鎮