

1

2

3

4

Notes: (Unless Otherwise Specified)

- 1. Waterproof Rate : IP67
- 2. Recommend Panel Thickness: 0.8 To 4.0 mm.
- 3. Recommend Torque: 14~15 Kgf-cm.
- 4. DWV: 500 Vrms
- 5. Rated Voltage: 30V AC/DC
- 6. Insulation Resistance: 100 MΩ MIN.
- 7. RoHS Compliant.

REV	ECN#	DESCRIPTION OF REVISION	DRAW BY DATE	CHECK BY DATE	APPROVE BY DATE
01		PRELIMINARY	Hank 12/13/17	Lucas 12/13/17	Ray 12/13/17

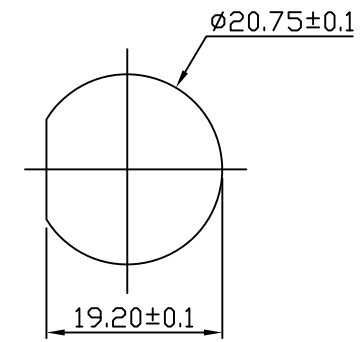
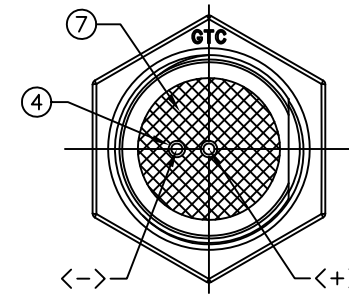
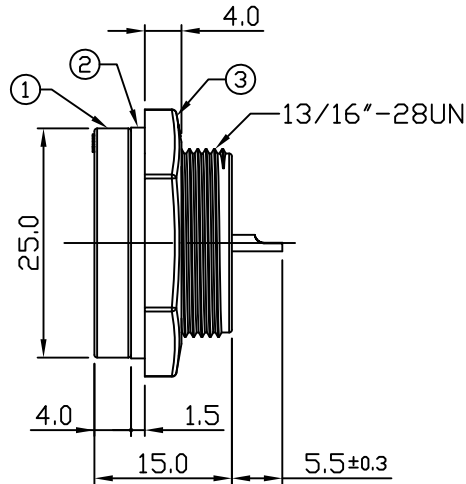
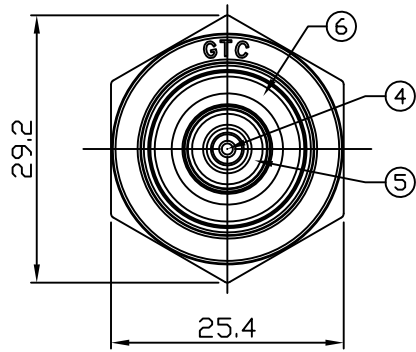

Recommend Panel Cut-Out

7	Glue	Epoxy Color: Black	
6	Metal Ring	SUS430 Finish: -	1
5	Contact Ring	Copper Alloy Finish: Au Plated	1
4	Contacts	Copper Alloy Finish: Au Plated	2
3	Hex Nut	Thermoplastic Color: Black	1
2	Gasket	Silicone Color: Black	1
1	Housing	Thermoplastic Color: Black	1
Item	Part Name	Material / Finish	Q'ty

TITLE						DRAWING NUMBER			REV.	
Magnetic 5A 2 Contacts rotating 360 degrees Panel Solder						GT193000-02020			01	
	B	1:1	Hank 12/13/17	Lucas 12/13/17	Ray 12/13/17	X.X ± 0.5 X.XX ± 0.2	X.XXX ± 0.05 ANGLES ± 1°	mm	1/1	
THIRD ANGLE PROJECTION	SIZE	SCALE	DRAW / DATE	CHECK / DATE	APPROVE / DATE	TOLERANCES		UNIT	SHEET	

GT Contact CO.,LTD

NOTICE OF PROPRIETARY PROPERTY:
 THE INFORMATION CONTAINED HEREIN IS THE PROPRIETARY PROPERTY OF GT Contact CO.,LTD THE POSSESSOR AGREES TO THE FOLLOWING:
 (O) TO MAINTAIN THIS DOCUMENT IN CONFIDENCE
 (O) NOT TO REPRODUCE OR COPY IT
 (O) NOT TO REVEAL OR PUBLISH IT IN WHOLE OR PART
 (O) ALL RIGHTS RESERVED

1

2

3

4